

IWF RULES FOR COMPETITIONS

BOOK 3. MATERIAL RULES

	Article
PART 1. FENCERS' WEAPONS AND EQUIPMENT	
CHAPTER 1. WEAPONS	
Characteristics common to all weapons	m.1
General description	m.2
Dimensions	m.3
The handle	m.4
The guard	m.5
Foil	
Weight	m.6
Length	m.7
The blade	m.8
The guard	m.9
Electric wire	m.10
Pointe d'arrêt	m.11
Method of affixing the button	m.12
The insulation of the button, the blade and the handle	m.13
Epée	
Weight	m.14
Length	m.15
The blade	m.16
The guard	m.17
Electric wires	m.18
Pointe d'arrêt and button	m.19
Method of affixing the button	m.20
Sabre	
Length	m.21
Weight	m.22
The blade	m.23
The guard	m.24

CHAPTER 2. EQUIPMENT, CLOTHING AND WHEELCHAIR	
General conditions	m.25
Rules specific to foil	
Glove	m.26
Mask	m.27
Conductive jacket (over-jacket or plastron)	m.28
Bodywire and attachment plugs	m.29
Rules specific to épée	
Mask	m.30
Bodywire	m.31
Rules specific to sabre	
Mask	m.32
Glove	m.33
Conductive jacket and conductive t-shirt	m.34
Bodywire and plugs	m.35
CHAPTER 3. CHECKING OF MATERIAL	
Competence	m.36
Checking of fencers' equipment	m.37
Presentation of equipment to the Weapon	
Checking Centre	m.38–39
Checking body	m.40–41
Checking personnel and equipment	m.42–43

**PART 2. FITTINGS AND MATERIAL PROVIDED
BY THE ORGANISERS**

Introduction	m.44
CHAPTER 1. SCORING APPARATUS	
Authorised designs	m.45
Approval of designs of apparatus	m.46–50
Requirements for all electrical equipment	m.51
Number and quality of judging apparatus	m.52
Checking of apparatus	m.53–54
CHAPTER 2. SPOOLS, CABLES AND THEIR CONNECTIONS	m.55–56
CHAPTER 3. CONDUCTIVE PISTES	m.57
CHAPTER 4. SOURCE OF ELECTRICAL CURRENT	m.58
CHAPTER 5. EXTENSION LAMPS	m.59–60
CHAPTER 6. FENCING FRAMES	m.61
CHAPTER 7. APRONS LAMÉ	m.62

ANNEXES A, B AND C TO THE MATERIAL RULES / PUBLICITY CODE

BOOK 3. MATERIAL RULES

REMARK: Throughout the Rulebook

- **IWF** stands for **IWAS Wheelchair Fencing**
- **IWF EC** stands for **IWAS Wheelchair Fencing Executive Committee**
- words importing singular number or masculine gender shall include the plural number or feminine gender, as the case may be, and vice versa

PART 1. FENCERS' WEAPONS AND EQUIPMENT

CHAPTER 1. WEAPONS

CHARACTERISTICS COMMON TO ALL WEAPONS

- m.1.**
1. There are three types of weapon: foil, épée and sabre.
 2. All weapons are authorised providing only that they conform to these regulations and to the safety standards which are annexed.
 3. The weapon should be so constructed that it cannot normally injure either the user or his opponent. All methods of treating a blade between the guard and the tip (button), by grinding, filing or other methods, are forbidden.
 4. Sharpening the edges or angles of the point is forbidden.

General description

- m.2.** All weapons are composed of the following parts.
1. A flexible steel blade completed at its forward extremity by a button and at the rear by the tang (the latter included in the handle when the weapon is mounted).
 2. A handle within which the tang of the blade is fixed by a locking nut or in any other way, and which enables the fencer to hold the weapon. It may be composed of one or several parts: in the latter case it is divided into a grip (which is normally held in the hand) and a pommel (rear portion of the handle which locks the handle onto the tang).
 3. A metal guard fixed (with the convex face towards the front) between the blade and the handle, serving to protect the sword hand. The guard may contain a padding or cushion (cf. m.5/2) to reduce the effect of blows. It will also contain a socket to which the bodywire can be connected.

Dimensions (cf. m.7ss, m.15ss, m.21ss)

- m.3.** Each weapon has its particular design and measurements.
1. The length of the blade includes the button and everything which is added in front of the convex surface of the guard whether or not it is fixed to the latter.

2. The total length of the weapon and its various parts corresponds to the distances between lines (planes) drawn parallel to each other and perpendicular to the axis of the blade. These lines are situated:
 - a) A at the forward extremity of the weapon
 - b) B at the point where the blade leaves the front, convex, surface of the guard
 - c) C at the back of the aforesaid guard
 - d) D between the grip and the pommel
 - e) E at the rear extremity of the handle
3. The total length of the weapon is the distance between lines A and E; the length of the blade that between A and B; the length of the handle that between B and E; and the depth of the guard that between B and C.
4. The maximum total length of the weapon must be less than the greatest permissible length for the blade and the handle added together. These two latter lengths must, therefore, complement each other to arrive at the total length of the weapon.
5. In order to measure either the total length of the weapon or the length of the blade, it is essential that the latter should be without any curve. When measurements are being made, the blade should therefore be held straight on a flat surface.
6. Only the pommel or the locking nut may be placed between lines D and E.

The handle

- m.4.**
1. The maximum length of the handle at foil and épée is 20 cm, measured between lines B and E, and 18 cm, measured between lines B and D. At sabre the maximum length of the handle is 17 cm (see Figures 8, 9 and 13, pp. 11, 14, 21).
 2. The handle must be able to pass through the same gauge as the guard. It must be so made that normally it cannot injure either the user or his opponent.
 3. All types of handle are allowed providing that they conform to the regulations which have been framed with a view to placing the various types of weapons on the same footing. However, at épée, orthopaedic handles, whether metal or not, may not be covered with leather or any material which could hide wires or switches.
 4. The handle must not include any device which assists the fencer to use it as a throwing weapon.
 5. The handle must not include any device which can increase in any way the protection afforded to the hand or wrist of the fencer by the guard: a cross bar or electric socket which extends beyond the edge of the guard is expressly forbidden.
 6. If the handle (or glove) includes any device or attachment or has a special shape (orthopaedic) which fixes the position of the hand on the handle, the handle must conform to the following conditions.
 - a) It must determine and fix one position only for the hand on the handle.
 - b) When the hand occupies this one position on the handle, the extremity of the thumb when completely extended must not be more than 2 cm from the inner

surface of the guard.

The guard (cf. m.9, m.17, m.24)

- m.5**
1. The convex face of the guard must have a shape and surface which is both smooth and not too shiny. It must be so made that it can neither hold nor catch the opponent's point. It must not have a raised rim.
 2.
 - a) Inside the guard there must be a cushion (padding) sufficiently wide to protect the electric wires from the fencer's fingers. The padding on the inside of the guard must be less than 2 cm thick and must be arranged in such a way as not to increase the protection which the guard affords the hand.
 - b) The connections must be so arranged that it is impossible for the fencer to break or make contacts while fencing.
 - c) On foils, the wire must be protected by an insulating sheath.
 - d) On épées, the two wires must be protected by two insulating sheaths, one on each wire.
 - e) Both the wire and the insulating sheath must go right up to the socket.
 - f) In no case may uninsulated wires project beyond the point where they are attached to the socket (cf. m.29, m.31).
 3. Any system of attachment inside the guard is allowed, provided that it conforms to the following requirements.
 - a) It must be easy to detach or attach the bodywire.
 - b) It must be possible to check it by a simple method such as using a penknife or a coin.
 - c) It must be easy to apply the pointe d'arrêt of the opponent's weapon to the earth circuit connected to the blade.
 - d) It must have a security device which prevents the bodywire from becoming unplugged during the bout.
 - e) It must ensure the complete connection of the electric wires; it must be impossible for even a momentary break of contact to occur while the plugs are connected.
 - f) It must not include any part which allows electrical contact to be made between the plug sockets.
 4.
 - a) The maximum electrical resistance allowed for foil and épée is 2 ohms.
 - b) Those who wish to assemble electric weapons, but who are not equipped to undertake electrical tests, are advised that the limits for the electrical resistance for the circuits laid down for each weapon have been fixed so that they can be attained by anyone who is reasonably careful.
 - c) They are advised:
 - i) thoroughly to de-oxidise the external surface of the guard and the connecting surfaces inside it;
 - ii) not to destroy the insulation of the wires, especially where they pass along

- the groove in the blade at the point and at the guard;
- iii) to avoid accumulations of glue in the groove of the blade.

Equipment and Checking of Weapons

5. a) At foil and épée, only traditional or homologated pointes d'arrêt are accepted. No other kind of pointe d'arrêt, notably new ones that are not homologated, will be accepted at the weapon control.

In order to make the identification easier, please note that a traditional pointe d'arrêt has two screws to fix the tip of the pointe d'arrêt to the base, the whole is in metal and there is no plastic in the base.

To make the checking of weapons easier and allow the complete observation of the tip and its base, foil fencers are requested to present their foils with bare points not covered with adhesive tape over the first 15cm.

- b) In order that the registering of hits by the contact of the point on the opponent be correctly registered by the scoring device, the pointes d'arrêt must be clean. The electrical resistance measured in ohms must not exceed the limit of two ohms (m.5.4.a).

- c) The blades, the guards at épée and foil and the guard at sabre must be totally of metal. Apart from at sabre where the part of the guard next to the pommel is insulated (insulating sheath), their exteriors must not be covered by any material (plastic or other).

The guard may not feature any advertising. This is also the case for the insulated part of the sabre guard.

- d) Any fencer or other person who tries to register hits in a way that does not comply with the rules, either with the weapon or by manipulating the scoring device, will be excluded from the competition or from the competition zone and, after identification, will be liable to further penalty.

FOIL

Weight

- m.6.** The total weight of the foil ready for use must be less than 500 g.

Length

- m.7.** The maximum total length of the foil is 110 cm.

The blade

- m.8.** 1. The blade, which is rectangular in section, must be made of steel complying with the safety standards described in Annexe A to the Rules.
2. The edges must be smoothed off so that they will not cut, and must be chamfered at an angle of 45° ($\pm 5^\circ$), 0.5 mm on each side (± 0.1 mm), so that they will neither cut nor become capable of cutting.
3. The blade is mounted with the widest face placed horizontally.
4. The maximum length of the blade is 90 cm (cf. m.3).

5. The blade should have a flexibility equivalent to a bend of minimum 5.5 cm and maximum 9.5 cm measured in the following way.
 - a) The blade is fixed horizontally at a point 70 cm from the extremity of the button.
 - b) A 200 g weight is suspended 3 cm from the extremity of the button.
 - c) The bend of the blade is measured at the extremity of the button between the non-weighted and weighted positions (see Figure 8).
 - d) The groove in the blade must be uppermost.
6. The blade should be as straight as possible. Any curve of the blade must be uniform and the maximum bend must in any case be less than one cm; it is only permitted in the vertical plane and must be near the centre of the blade.

The guard (cf. m.5)

- m.9.** 1. The guard must be able to pass through a straight cylindrical gauge having a diameter of 12 cm and a length of 15 cm, the blade being parallel with the axis of the cylinder.
2. Eccentric mounting is forbidden, that is to say that the blade must pass through the centre of the guard. The diameter of the guard must be between 9.5 cm and 12 cm.

Electric wire

- m.10.** The foil has a single wire, glued in a groove cut the whole length of the blade, which permanently connects the pointe d'arrêt to the corresponding socket inside the guard.

Pointe d'arrêt

- m.11.** 1. The diameter of the pointe d'arrêt is between 5.5 mm and 7 mm; the diameter of the body of the button including its exterior insulation must not be more than 0.3 mm less than that of the pointe d'arrêt.
2. The pointe d'arrêt must be cylindrical; its front surface is flat and perpendicular to its axis. Its edge will either be rounded with a radius of 0.5 mm or have a chamfer of 0.5 mm at 45°.
3. The pressure required on the pointe d'arrêt, in order to break the contact and cause the apparatus to register a hit, must be more than 500 g, that is to say that this weight must be lifted by the spring of the point. The weight of 500 g supplied by the Organising Committee may have a tolerance of ± 2 g, i.e. 498–502 g.
4. The course or stroke of the pointe d'arrêt required to cause the electrical apparatus to register a hit, called the *lighting stroke*, may be infinitesimal: the total stroke of the pointe d'arrêt must not be greater than 1 mm.
5. The pointe d'arrêt must be retained in the button in at least two places equidistant from each other, or by any other method which has been approved by the SEMI Committee of the FIE.
6. When not depressed the pointe d'arrêt is in contact with the main body of the foil. When a hit is made, this contact must be broken.

DIMENSIONS OF THE FOIL
(Articles m.3–m.8)

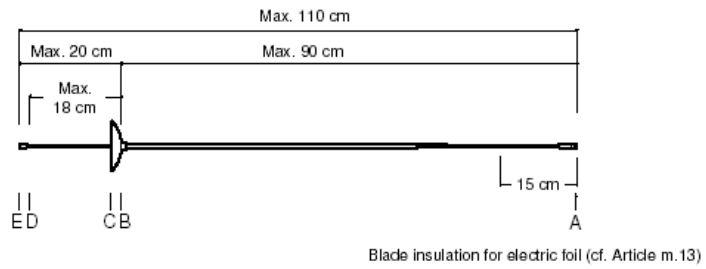

FOIL GUARD
(Article m.9)

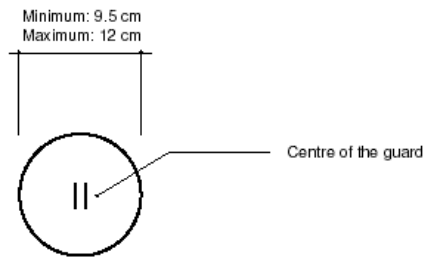

THE FOIL

The total weight of the foil must be less than 500 g (Article m.6)

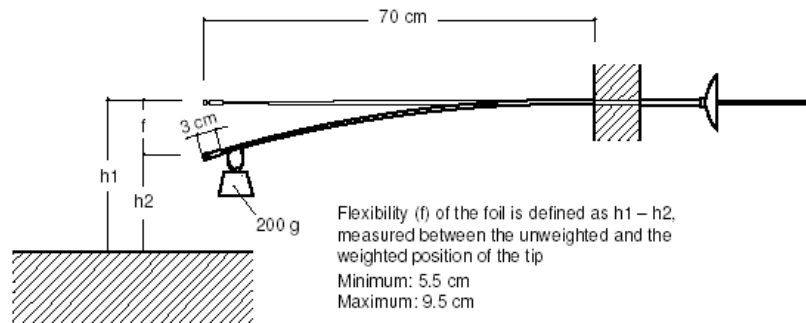

Figure 8. Foil dimensions and flexibility

Method of affixing the button

- m.12.** 1. If the base of the button is not made in one piece with the blade, or if it does not permit the flattened piece at the tip of the blade to be retained, it must be screwed onto the end of the blade, which must be cut and threaded for this purpose under the following conditions.
2. Normally, only fixing by metal to metal is allowed. However, fixing by any insulating material of great mechanical strength may be authorised after approval by the SEMI Committee of the FIE.
 3. All methods of soldering or brazing or in general any heating which may affect the temper of the blade are forbidden. Only solder of very easily melted tin, used with a soldering iron, to prevent the tip from coming loose, is authorised.
 4. The end of the blade before cutting the thread must not have a diameter at any point of less than 3.5 mm, and this without anything being wrapped round it, a process which is strictly forbidden.
 5. The diameter of the core of the thread must not be less than 2.7 mm (thread SI $3.5 \infty 0.60$). The threading must be very tight.
 6. The part of the blade on which the button is fixed should be of a length of 7–8 mm entirely covered by the button. It is recommended that only the half of this length at the extremity of the blade be threaded. For the other half the button will have a smooth surface of 3.5 mm diameter into which it should take some force for the corresponding part of the blade to be introduced.
 7. When a button made of light alloy is used, instructions should be sought from the SEMI Committee of the FIE.
 8. At the point at which the wire passes into the button, the width of the groove must not exceed 0.5 mm, and its depth must not exceed 0.6 mm measured on the diameter of the core of the thread, in order to weaken as little as possible the section of the blade.
 9. Only the members of the SEMI Committee of the FIE or the Directoire Technique can require the verification of the above points.

The insulation of the button, the blade and the handle

- m.13.** 1. The body of the button and the foil blade for a length of 15 cm from the button, as well as the pommel or the rear extremity of the handle, must be entirely covered with insulating material (insulating tape, gummed paper, Sellotape, plastic material or varnish).
2. The flange of the sleeve which slides in the base of the point and within which is fixed the pointe d'arrêt must be of a smaller diameter than the insulated head of the pointe d'arrêt itself, to obviate an accidental contact being made with the conductive jacket when a hit is made.

EPEE

Weight

- m.14.** The total weight of the épée ready for use is less than 770 g.

Length

- m.15.** The total maximum length of the épée is 110 cm.

The blade

- m.16.** 1. The blade, which is triangular in section without cutting edges, is made of steel and must comply with the safety standards described in Annexe A to the Rules.
- There are two methods of manufacture (see Figure 9):
- By forging a steel cylinder (Cross-section of blade, A);
 - By folding a sheet of steel (Cross-section of blade, B).
2. It should be as straight as possible and mounted with the groove uppermost. Any curve of the blade must be uniform and the maximum bend must in any case be less than 1 cm; it is only permitted in the vertical plane and must be near the centre of the blade.
3. The maximum length of the blade is 90 cm.
4. The maximum width of any of the three sides of the blade is 24 mm.
5. The blade should have a flexibility equivalent to a bend of 4.5 cm minimum and 7 cm maximum measured in the following way.
- a) The blade is fixed horizontally at a point 70 cm from the extremity of the button.
 - b) A 200 g weight is suspended 3 cm from the extremity of the button.
 - c) The bend of the blade is measured at the extremity of the button between the non-weighted and weighted positions (see Figure 9, opposite).

The guard (cf. m.5)

- m.17.** 1. The guard, which must have a circular edge, must be able to pass through a cylindrical gauge having a diameter of 13.5 cm and a length of 15 cm, the blade being parallel to the axis of the cylinder. The depth of the guard (the distance between lines B and C) must be between 3 cm and 5.5 cm (cf. m.3).
2. The total length between lines A and C must never be greater than 95.5 cm (cf. m.3).
3. Eccentric mounting is allowed provided the distance between the centre of the guard and the point where the blade passes through the guard does not exceed 3.5 cm.

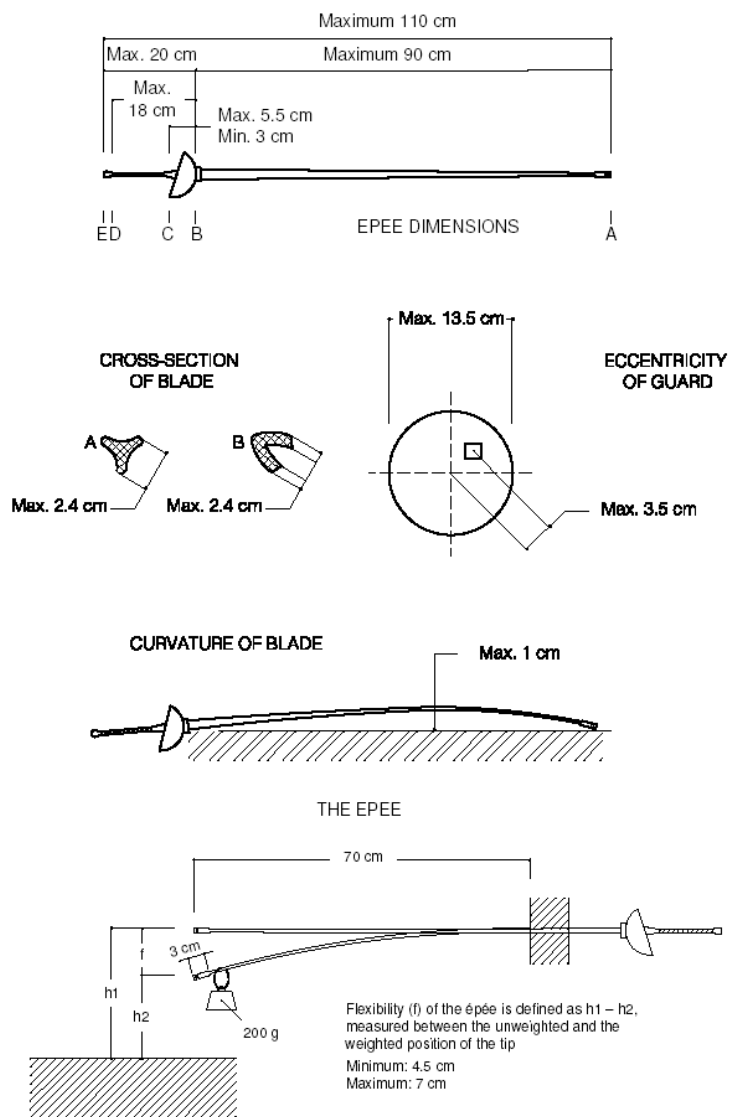

Figure 9. Epee dimensions and flexibility

Electric wires

- m.18.** The epee has two electric wires, glued in a groove in the blade, which connect the button to two of the three sockets situated inside the guard and which form the active circuit of the epee. The body of the epee is connected to the third socket.

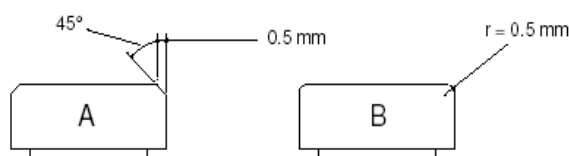

Figure 10. Épée: design of pointes d'arrêt

Pointe d'arrêt and button

- m.19.** 1. The electric button is completed by a pointe d'arrêt which must conform to the following specifications.
- The pointe d'arrêt is cylindrical. Its front surface is flat and perpendicular to its axis. Its edge will either be rounded with a radius of 0.5 mm or have a chamfer of 0.5 mm at 45° (see Figure 10).
 - The diameter of the crown of the pointe d'arrêt is 8 mm with a tolerance of ± 0.05 mm. The diameter of the base must not be less than 7.7 mm.
 - The flange (collar) which guides the pointe d'arrêt as well as the insulating washer must be sufficiently recessed in relation to the crown (it is recommended that it be recessed in diameter by 0.3– 0.5 mm) so that it shall not be possible to cause a hit to be registered merely by sliding the depressed pointe d'arrêt against the convex surface of the guard (see Figure 11) (cf. t.67.a).

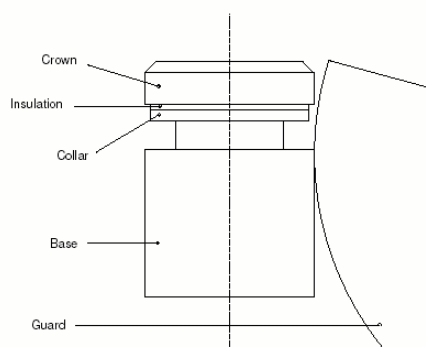

Figure 11. Épée: details of tip of point

- The pressure required on the pointe d'arrêt in order to complete the circuit in the épée, and thus cause the apparatus to register a hit, must be more than 750 g, that is to say that this weight must be lifted by the spring of the point.

3. The weight used to check competitors' épées on the piste consists of a metal cylinder drilled part of the way along its axis with a hole parallel to its sides; this hole, into which is inserted the end of the blade, must have an insulating lining to prevent its metallic parts coming into contact with the earthed mass of the épée which might then give a false result to the test.

This weight of 750 g, which is supplied by the Organising Committee, may have a tolerance of ± 3 g, i.e. 747–753 g.

4. a) The course or stroke of the pointe d'arrêt required to complete the circuit in the épée and thus cause the apparatus to register a hit, called the *lighting stroke*, must be greater than 1 mm. The further course which the pointe d'arrêt may travel must be less than 0.5 mm. (This requirement is just as essential as that for the lighting stroke.)
 - b) To enable a check to be made on the piste, the total course or stroke of the point must be greater than 1.5 mm (cf. t.43).
 - c) Adjusting the lighting stroke by means of screws or any other external fixing device, once the point has been assembled on the weapon, is forbidden.
 - d) An external screw or similar fixing device is only allowed if it is actually part of the assembling of the point.
 - e) The head of the screw or fixing device must never project beyond the flat top surface of the point and its housing in the flat surface may not exceed 2 mm in diameter.
5. The pointe d'arrêt must be retained in the button at at least two points equally spaced, or by any other system approved by the SEMI Committee of the FIE.
6. When there is a hit, the electrical contact must be established.

Method of affixing the button

- m.20. If the base of the button is not made in one piece with the blade, or if it does not permit the flattened inset piece at the tip of the blade to be retained, the button must be screwed onto the end of the blade, which must be cut and threaded for this purpose under the following conditions.
 1. Normally, only fixing by metal to metal is allowed. However, fixing by any insulating material of great mechanical strength may be authorised after approval by the SEMI Committee of the FIE.
 2. Only solder of very easily melted tin, used with a soldering iron, to prevent the tip from coming loose, is authorised.
 3. The end of the blade, before cutting the thread, must not have a diameter at any point which is less than 4 mm and this without anything being wrapped round it, a process which is strictly forbidden.
 4. a) The diameter of the core of thread at the end of the blade must not be less than 3.05 mm (thread SI 4.0 ∞ 0.70).

- b) The part of the blade on which the button is fixed should be of a length of 7–8 mm entirely covered by the button. It is recommended that only the half of this length, at the extremity of the blade, be threaded. For the other half the button will have a smooth surface of 4.0 mm diameter into which it should take some force for the corresponding part of the blade to be introduced.
- 5. The groove necessary to enable the wires to enter the button must be cut in such a way that it weakens as little as possible the section of the blade.
- 6. Only the members of the SEMI Committee of the FIE or the Directoire Technique can require the verification of the above points.

SABRE

Length

- m.21.** The total maximum length of the sabre is 105 cm.

Weight

- m.22.** The total weight of the sabre ready for use is less than 500 g.

The blade (see Figure 13)

- m.23.**
 - 1. The blade, which must be of steel, is approximately rectangular in section. The maximum length of the blade is 88 cm. The minimum width of the blade, which must be at the button, is 4 mm; its thickness, also immediately below the button, must be at least 1.2 mm.
 - 2. The end of the blade must be folded over onto itself or be fashioned in one piece to form a button which, viewed end on, must have a square or rectangular section of 4 mm minimum and 6 mm maximum. The maximum dimension must be not more than 3 mm from the end of the blade.
 - 3. The end of the blade may also be formed by a solid button which must have the same section as the button which is folded over (Figure 12, p.20).
 - 4. If the blade has a curve, it must be a distinct curve which must be continuous, and the deflection must be less than 4 cm. Blades with sharply bent extremities or which curve in the direction of the cutting edge are forbidden.
 - 5. The sabre blade must have a flexibility equivalent to a bend of minimum 4 cm and maximum 7 cm measured in the following way.
 - a) The blade is fixed horizontally at a point 70 cm from the tip of the blade.
 - b) A 200 g weight is hung 1 cm from the tip.
 - c) The curve is measured at the tip of the blade between the weighted and unweighted positions (see Figures 12 and 13).

FLEXIBILITY OF THE SABRE BLADE

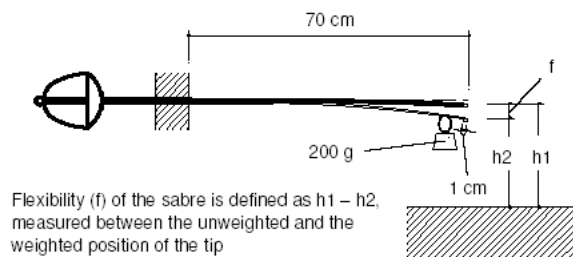

Flexibility (f) of the sabre is defined as $h1 - h2$, measured between the unweighted and the weighted position of the tip

Minimum: 4 cm
Maximum: 7 cm

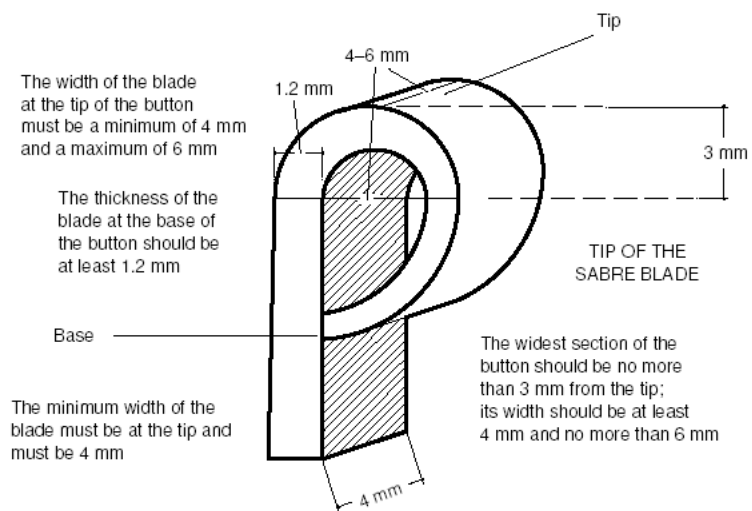
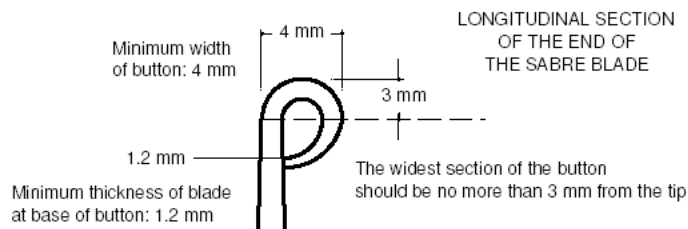

Figure 12. Sabre dimensions and flexibility

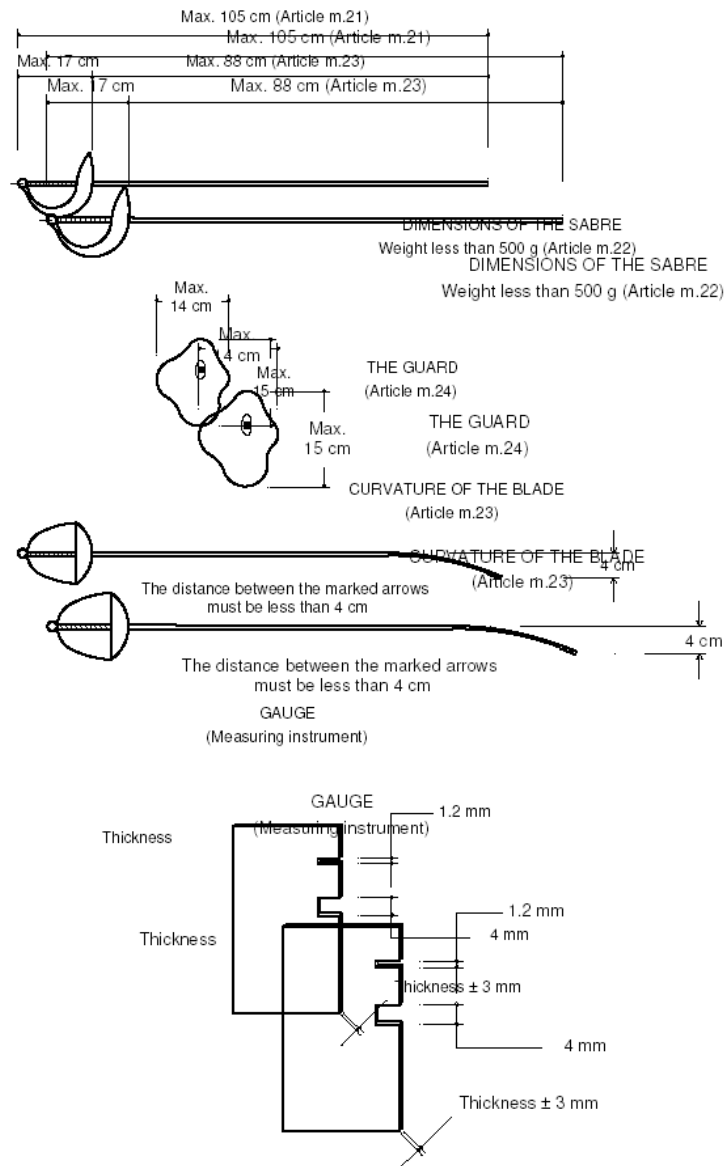

Figure 13. Sabre dimensions (contd.)

The guard (cf. m.5)

- m.24.** 1. The guard must be full in shape, made in one piece and externally smooth. It must have a convex form which is continuous, without rim or holes.
2. It must be able to pass through a rectangular gauge measuring 15 cm by 14 cm in section, with a length of 15 cm, the blade being parallel with the axis of the gauge.
3. Inside the guard there must be a socket into which the bodywire is plugged, whatever system is used.
4. The two sockets of the bodywire plug must be in direct contact with the body of the guard, making a closed electrical circuit through the bodywire, the spool and the cable connecting the spool to the scoring apparatus.
5. The resistance in the weapon must not exceed 1 ohm.
6. The interior of the guard must be completely insulated by means of insulating paint or a pad.
7. The exterior of the guard must be insulated for 7–8 cm from the pommel.
8. The handle and the pommel must be completely insulated.

CHAPTER 2. EQUIPMENT AND CLOTHING

GENERAL CONDITIONS

- m.25.** The national uniform includes the socks, the breeches, the jacket, and the conductive jacket at foil and sabre (cf. m.28, m.34).

1. Protection

The equipment and clothing must provide the competitor with the maximum protection compatible with the freedom of movement necessary for fencing.

2. Safety

It must not be possible for the opponent to be obstructed or injured by the equipment, nor for it to have either buckles or openings in which the opponent's point may be caught up — except accidentally — and thus held or deflected. The jacket and its collar must be completely buttoned or done up.

3. Characteristics of the clothing

- a) Fencers' clothing must be made of sufficiently robust material and be clean and in good condition.
- b) The material from which the equipment is made must not have a surface which is smooth enough to cause the pointe d'arrêt, the button or the opponent's hit to glance off (cf. m.30).
- c) Clothing must be made entirely in cloth able to resist a pressure of 800 Newtons. Very particular attention must be paid to the way the seams under the armpits, if there are any, are made. An under-garment consisting of a protective under-plastron covering the vital upper areas of the body (following the design given in Annexe A to these Rules, 'Safety norms for

manufacturers') resistant to 800 Newtons is also obligatory.

- d) Fencers' clothing may be of different colours, apart from black.
- e) There shall be only one national uniform per country.
- f) Logos (national strips) worn on the national clothing must be approved by the FIE Executive Committee at least 30 days before they are used for the first time in an official IWF competition; they are then published on the FIE website.
- g) For the following events, the wearing of national strips (logos) is compulsory on both rear wheels, optional on the arm(s). All the logos worn by any one fencer must be identical.
 - i) World Championships: every bout, in the pools, in the direct elimination and in team matches;
- h) The name of the fencer must be displayed on the back of the jacket, with the abbreviation of the national federation below it, at the level of the shoulder blades. They must be printed directly onto the jacket or onto a cloth carefully sewn onto the jacket.

The letters must be in dark blue, in capitals, between 8 cm and 10 cm high, and between 1 cm and 1.5 cm wide, according to the length of the name.

4. Jacket

- a) At all weapons, for men and ladies, the lower edge of the jacket must overlap the breeches by at least 10 cm when the fencer is in the on-guard position (cf. m.28, m.34).
- b) The jacket must include a lining making a double thickness of material for the sleeve down to the elbow of the sword arm and covering the flank up to the region of the armpit. At épée the fencer is required to wear a regulation jacket, which must cover the whole of the surface of the trunk.
- c) The use of a breast/chest protector (made of metal or some rigid material) is compulsory for women and optional for men.

At foil, this breast/chest protector must be worn below the protective plastron.

5. Breeches

- a) The breeches must be fastened below the knees.
- b) With breeches, the fencer must wear socks which cover the legs right up to the breeches. These socks must be held up in such a way that they cannot fall down.
- c) The fencer is permitted to wear socks with a turn-over showing the colours of his national team 10 cm high.

6. *Glove*

At all weapons, the gauntlet of the glove must, in all circumstances, fully cover approximately half the forearm of the competitor's sword arm to prevent the opponent's blade entering the sleeve of the jacket.

7. *Mask*

- a) The mask must be made with meshes (space between the wires) of maximum 2.1 mm and from wires with a minimum gauge of 1 mm diameter. The mask must include a safety strap at the rear.
- b) Masks, at all weapons, must be made in accordance with the safety standards described in Annexe A to these Rules and must carry the quality label specified in those standards.
- c) When the checks are carried out the person responsible for them may, if in doubt, ensure that the mesh of the mask, both at the front and at the sides, is able to withstand, without permanent deformation, the introduction of a conical instrument, the angle of the surface of the cone being at 4° to the axis and at a pressure of 12 kg.
- d) A mask which does not comply with the safety requirements laid down in this article will be rendered visibly unusable by the weapon checking personnel or the Referee in the presence of the person who presented the mask to the weapon check or the team captain of the fencer concerned.
- e) The bib of the mask must be made with cloth resistant to 1600 Newtons.

8. *Leg prostheses*

Leg prostheses have to be removed during a bout.

9. *The Fencing Wheelchair*

1. The wheelchair is part of fencing equipment and must be 'weapon controlled'. The back of the wheelchair, the cushion, the frame, the armrest and the wheels will be tagged with a matching numbered marker by the controller. The material of the back of the wheelchair and that of the seating (but not that of the cushion) can be rigid or flexible.
2. All of the back of the wheelchair must have a minimum height of 15cm from the seat of the chair or the cushion when the fencer is seated upon it, and must be 90° to the horizontal. (+2°). For wheelchair fencers who have a physical need for the back and the material be changed from 90° to the horizontal. (+2°), it is the decision of the wheelchair controller and a classifier.
3. No side guard to be used on the fencing arm side of the wheelchair at any time during competition.
4. The side guard on the non-fencing arm of the wheelchair must have a minimum height of 10 cm from the seat of the wheelchair or the cushion, when the fencer is seated upon it, and a minimum length of 20 cm beginning at the back of the chair. This side guard must be securely and correctly fixed and of rigid material. (Tapes to secure the side guard will not be accepted)

5. The wheelchair must be fully insulated by permanent durable insulation coating or by the use of a detachable covering. When a covering is used it must be of robust construction and securely fixed.
6. A cushion is not obligatory. When a cushion is used it must be of the same dimensions as the seat of the wheelchair. The maximum cushion thickness is 10cm and must have an even thickness and not wedge-shaped and must be able to bend corner to corner by the wheelchair controller. A medical cushion must be authorised by the classifier.
7. The maximum height of the wheelchair must be 53cm from the floor to the full area of the seat rail, the width of the seat must not exceed 3 cm from the fencers hips when the fencer is seated in the centre of the wheelchair.
8. The camber of the wheels must fit the official wheelchair-fencing frame. (cf. m.61)
9. Strapping of the fencer to the wheelchair is permissible. The strip must not cover the valid target.

RULES SPECIFIC TO FOIL

Glove (cf. m.25)

- m.26.** The glove may be slightly padded.

Mask (cf. m.25)

- m.27.** The mesh of the mask must not extend below the chin. It must be insulated internally and externally by a plastic material resistant to impact.

Conductive jacket (over-jacket or plastron)

- m.28.** 1. The conductive surface of the conductive over-jacket which is worn over the protective jacket must cover the valid target of the fencer (cf. t.47) entirely and without omission when standing upright, when in the on-guard position and when lunging.
2. Whatever the means of fastening used, the conductive material must cover a sufficient area to ensure that it covers the valid target in all positions of the fencer. The overlap must always be on the swordarm side.
3. The interior of conductive jackets must be electrically insulated by a lining or by an adequate treatment of the conductive lamé material.
4. The conductive collar must have a minimum height of 3 cm.
5. The lamé material used must be of conductive thread in both warp and weft. As regards electrical conductivity it must conform to the following requirements.
- a) The electrical resistance measured between any two points of the lamé material must not be greater than 5 ohms. The resistance will be measured by using a 500 g copper or brass weight which has a hemispherical end with a radius of 4 mm. This weight, placed on this end and moved about on the lamé, must maintain continuous contact with a maximum resistance of 5 ohms.

- b) In no circumstances must the use of a conductive jacket be allowed if it has holes in it, or patches of oxidation or other defects which may prevent the registration of a valid hit.
 - c) A conductive jacket which is considered to be unusable will be so marked with a very visible coloured paint by a member of the SEMI Committee of the FIE.
6. The conductive jacket must be so made that when it is laid flat there is a straight line between the point of junction of the lines of the groin and the two points corresponding to the tops of the hip bones (ilium).
 7. The band of non-conductive material passing between the legs must be at least 3 cm wide (see Figure 14).

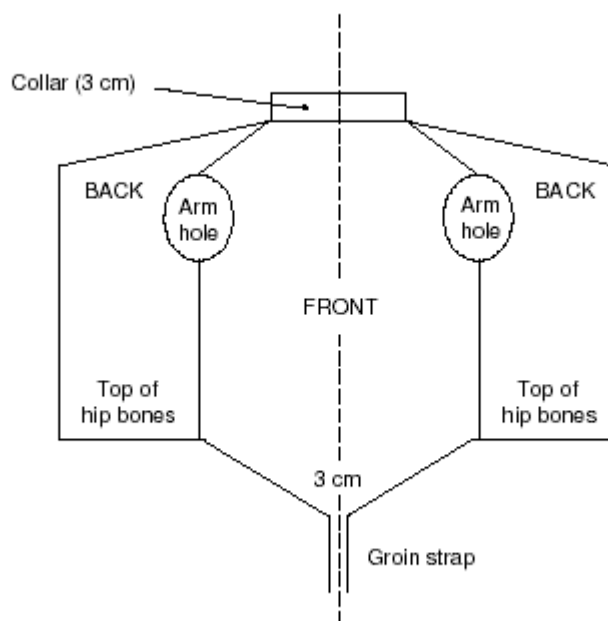

Figure 14. Foil: conductive jacket

Bodywire and attachment plugs

- m.29.** 1. a) The conductive wires of the bodywire (the fencers' personal equipment) must be well insulated electrically from each other, twisted or joined together, and not be affected by humidity.
- b) This bodywire has a connecting plug at each end.
- c) The electrical resistance of each of these conductive wires (plug to plug and plug to crocodile clip) must not exceed 1 ohm.
2. a) At the spool end the three-pin male plug, which must comply with the conditions of manufacture and assembly laid down in Article m.55, will be attached to the wires in the following manner:
- the pin at 15 mm from the centre pin to the conductive jacket;
 - the central pin to the wire in the weapon;
 - the pin at 20 mm from the centre pin to the foil earth circuit or the conductive piste.
- b) The wire which joins the rear connection of the bodywire to the conductive jacket by a crocodile clip must be separate for at least 40 cm. This wire must be soldered to the crocodile clip and this soldering must not be covered by any insulation or any material whatsoever. However, any method of fixing which presents the same guarantees as soldering may be used, provided it has been accepted by the SEMI Committee.
- c) The crocodile clip must be robust and ensure perfect contact with the conductive jacket. Its width at the point of contact must be at least 10 mm; the inside of the clip must leave a free space at least 8 mm long by 3 mm high. It must be clipped onto the back of the conductive jacket on the sword-arm side.
3. a) At the end nearest the foil, inside the guard, any method of attachment is allowed but the method adopted must always conform to the specification laid down in Article m.5.
- b) In addition, the pins of the plug must in no circumstances be able to touch the metal part of the guard.
- c) The wire from the point will be protected by an insulated sheath from the place where it enters the guard right up to the insulated connection on the plug socket. Under no circumstances may the non-insulated wire extend beyond this insulated plug connection (cf. m.5, m.9).

RULES SPECIFIC TO EPEE

Mask

- m.30.** 1. The mask must not be covered, in whole or in part, by material which can cause the point to glance off (cf. m.25).
2. The mask must be so shaped that the bib reaches below the prominences of the collar bones (clavicles).

Bodywire

- m.31.** 1. a) The conductive wires of the bodywire (the fencers' personal equipment) must be well insulated from each other, insensitive to humidity, and either joined or twisted together.
- b) The maximum electrical resistance allowed for each of these conductive wires from plug to plug is 1 ohm.
2. The bodywire has a connecting plug at each end.
3. At the spool end, a three-pin male plug is connected to the wire as follows:
- a) the pin 15 mm from the centre pin to whichever wire is most directly connected to the pointe d'arrêt;
- b) the centre pin to the other wire on the épée;
- c) the pin 20 mm from the centre pin to the épée's earth circuit and to the conductive piste.
4. This plug must conform to the conditions of manufacture and mounting specified in Article m.55.
5. Inside the guard the choice of system is free but the system chosen must comply with the conditions of Article m.5.
6. In addition, the pins of the plug must not on any account permit contact with the metal of the guard.
7. The two wires coming from the tip must be protected by two insulating sheaths, one for each wire, from the point where they enter the guard right up to the two insulated connections on the plug socket. In no case may uninsulated wires extend beyond the plug connections (cf. m.5, m.9).

RULES SPECIFIC TO SABRE

Mask

- m.32.** 1. The metal mesh of the mask must not be insulated and must ensure electrical conductivity.
2. The bib and any trim must be entirely covered with conductive material with the same electrical characteristics as the conductive jacket.
3. The trim may also be made of conductive material.
4. The electrical resistance between the crocodile clip and any point on the mask must be less than 5 ohms.
5. The electrical contact between the conductive jacket and the mask must be ensured by means of a wire and one or two crocodile clips. The wire must be attached, either by means of a crocodile clip or by being soldered, to the mesh of the mask, and must be between 30 cm and 40 cm long. The crocodile clip, the design and size of which must conform with the conditions laid down in Article m.29, must be soldered to the other end of the wire.

Glove

- m.33.** 1. The conductive material, which may be removable or fixed, of the regulation glove of the fencer's sword arm must cover all the sleeve down to below the external cubital styloid (small prominent bone of the wrist), both when the fencer is in the 'on-guard' position and when the sword arm is straight.
2. The conductive material must be turned over into the inside of the gauntlet to a depth of at least 5 cm.
3. In order to guarantee a good contact with the sleeve of the conductive jacket, it is necessary to use an elastic band, a popper button or any system which will guarantee conductivity and which has been approved by the SEMI Committee.

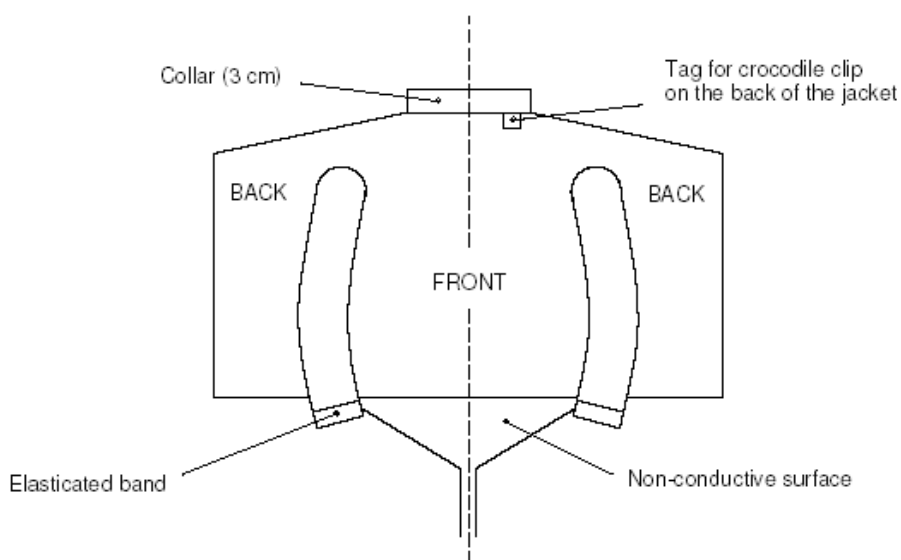

Figure 15. Electric sabre: conductive jacket

Conductive jacket and conductive t-shirt

- m.34.** 1. The fencer must wear, over his jacket, a conductive over-jacket, the conductive surface of which must cover entirely and without omission the valid surface of the body above a horizontal line which, when the fencer is on guard, joins, round the fencer's trunk, the upper points of the creases formed by the thighs. At wireless sabre the fencer must wear a conductive t-shirt. The conductive part is made of a conductive fabric with an electrical resistance which, measured between any two points of the conductive fabric, must be less than 5 ohms.
2. The conductive surface must cover the arms as far as the wrists. The jacket must have a collar which is at least 3 cm high. The jacket must have a conductive flap, 2 cm \times 3 cm in the middle of the back, just below the collar, to which the crocodile clip from the mask can be attached.

3. Whatever means of fastening is used, the conductive material must be ample enough to guarantee covering the valid target area in any position.
4. The conductive material (lamé) must satisfy the conditions laid down for testing (cf. m.28).
5. The sleeves of the conductive jacket must be fixed at the wrist by means of an elastic band. There must be a strap passing between the fencer's legs to keep the jacket in place (see Figure 15).

Bodywire and plugs

- m.35.** The fencer must use the bodywire specified for foil, plugged into the guard plug socket by means of any system which conforms with the conditions for manufacture and assembly laid down in Articles m.5, m.29 and m.55.

CHAPTER 3. CHECKING OF MATERIAL

COMPETENCE

- m.36.** 1. The checking of the electrical material used by the organisers for the World Championships and the fencing competitions of the Paralympic Games, as well as the checking of the fencers' equipment, must be supervised by the SEMI Committee.
2. To carry out this supervision, three members of the above-mentioned Committee must be appointed and put in charge of this work. However, when the organising country possesses somebody competent, two members of the above Committee will be appointed.
3. The delegates of the Committee for Electrical Apparatus and Equipment (SEMI) have the right at any time to seize a weapon, a bodywire, a conductive jacket or any item of equipment or clothing for examination.

CHECKING OF FENCERS' EQUIPMENT

- m.37.** 1. In all official IWF competitions the fencers are responsible for their equipment (including weapons and clothes) at the moment they present themselves on the piste.
2. In particular blades, masks and clothing must all carry the label of guarantee specified in the safety standards annexed to these Rules.
3. The forms of checking laid down by these Rules are only intended to help organisers who must apply the Rules and fencers who must always respect these Rules. These checks can, therefore, in no way absolve any fencers who break the Rules from responsibility.

Presentation of equipment to the Weapon Checking Centre

- m.38.** 1. Fencers are obliged to present themselves at the Weapon Checking Centre, at the time advised in the timetable of each official competition of the IWF, with the equipment they intend to use during the event referred to. The number of articles handed to the Checking Centre is limited to four weapons, two

bodywires, two conductive jackets, two masks and two mask-to-jacket leads per fencer.

2. Each competitor must submit his weapons in a fencing bag at the Weapon Checking Centre reception. An inventory of the equipment is made by an organising official and a label is put on the bag, indicating the name of the country of the competitor. The bags are stored in the order in which they arrive, and are checked in the same order.
3. Provision should be made for weapons and clothing to be submitted on the morning of the day before the competition. Having been checked, the material will be returned to the delegations at the end of the day.

Weapons, equipment and clothing presented to the Checking Centre after 5 p.m. on the day before each event may be refused.

4. Each head of delegation must indicate where he can be contacted should a serious fault be detected while the equipment belonging to his fencers is being checked.
5. If a weapon is found to be defective at the first check a form is attached indicating the fault: e.g. the length of the blade, the insulation, the spring of the point, cutting edges, etc. This form is completed at the second check. However, when a weapon is rejected, it must go through the entire cycle again.

- m.39.** 1. If material or equipment presented to the Checking Centre appears to have been assembled in such a way that the fencer can control at will the registering of hits or the malfunctioning of the judging apparatus, the representative of the SEMI Committee may, after the examination of the irregular items, require a penalty against the person who submitted them.
2. The fencers or the team captain can only insist on the return of the equipment which has been checked one hour before the start of the event.
 3. Any repairs to equipment rejected during the checking can be carried out in the repair workshop. Repaired equipment will, however, only be tested again after the first set of checks of the other fencers' equipment has been completed.

Checking body

- m.40.** 1. The IWF EC will appoint the member(s) of the SEMI Committee to be responsible for the checking of weapons, clothing and equipment of the fencers at the fencing competitions of the Paralympic Games and for the World Championships.
2. For other official IWF competitions the Organising Committee will appoint one or more persons to be responsible for this checking.

- m.41.** The items of equipment which have been thus checked will be distinctively marked. A fencer must not, on pain of penalties (cf. t.120), use any equipment which does not bear this check mark.

Checking personnel and equipment

- m.42.** 1. In order to allow those carrying out the checking to fulfil their task, the organisers are required to make available the equipment (gauges, weights, scales, electrical measuring machines, etc.) and the personnel necessary to

carry out the work.

2. The Organising Committee must provide the technical personnel responsible for checking the weapons and equipment with at least the following apparatus:
 - a) Two gauges allowing the lengths of blades and the depths and diameters of the guards at all weapons to be measured quickly.
 - b) Devices for measuring the flexibility of blades and the resistance of the mesh of masks.
 - c) An electrical checking device to check quickly that the electrical resistance of the point is not too high, and that the bodywire and the weapon are correctly assembled. Devices enabling these measurements to be taken easily are, in fact, commercially available.
 - d) Weights of 750 g and 500 g to test the springs of the points in épée and foil, in the workshop and at each piste.
 - e) A device allowing the lighting stroke and residual travel of épée points to be accurately measured, in the workshop and at each piste.
 - f) Labels to indicate that a weapon has been checked and that it satisfies the regulation, or has been rejected.
 - g) The organisers must provide a special stamp to be affixed to each conductive jacket to enable the referees to verify that its resistance in ohms has been checked by the technical delegates of the FIE. Nevertheless, this compulsory checking mark is not sufficient to justify the use of the jacket. In effect, it is the task of the Referee to check, before each event, that the conductive jacket, having been checked and marked, entirely covers the valid target area, and accordingly to make the final decision whether it may be used.
 - h) A special ink or paint must be provided to mark the guards, blades and points of weapons which have been checked. Nevertheless, those responsible may use other methods to mark the weapons and conductive jackets.
- m.43.** 1. To carry out the checks properly and rapidly, 'workshop' teams of three people should be used. (At least three such workshops should be provided.)
2. The first person checks that all the weapons are normal with respect to their dimensions by passing them through a gauge.
 3. The second does all electrical tests.
 4. The third affixes the checking marks and replaces the weapons in the fencing bag.

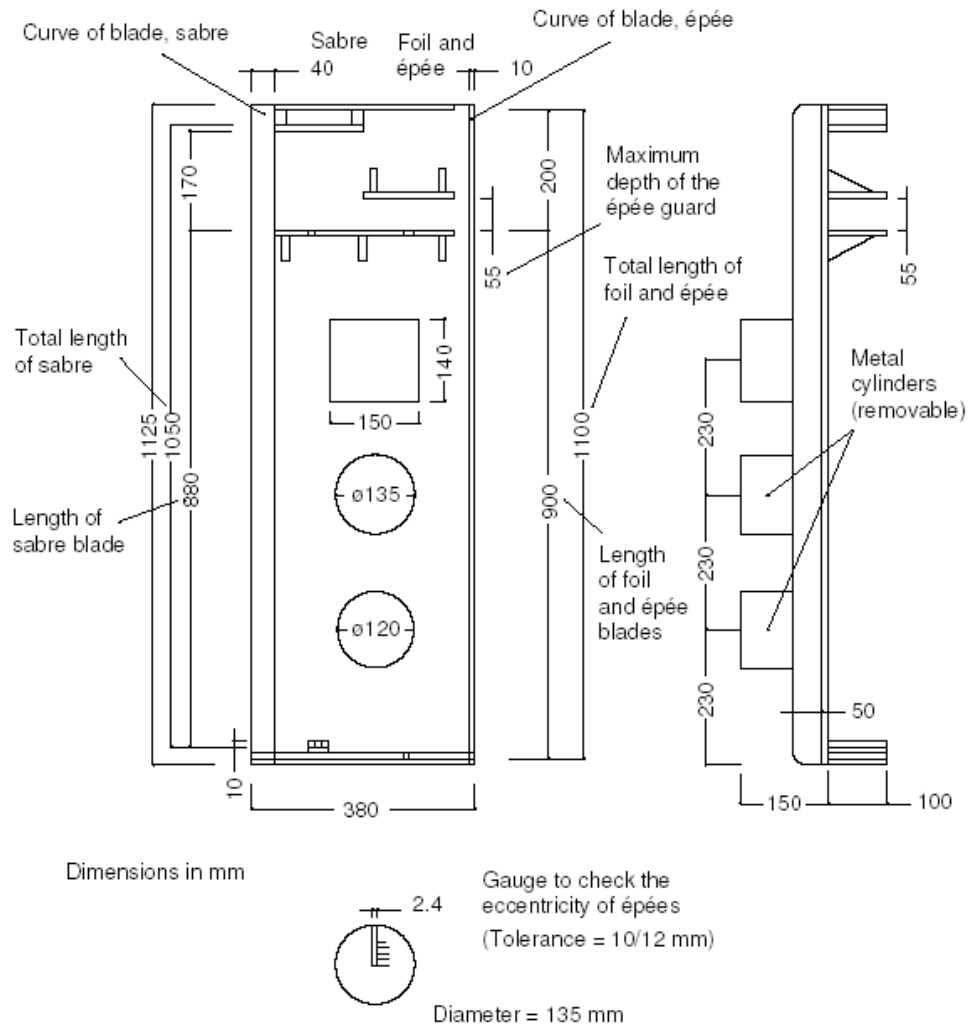

Figure 16. Gauge for checking weapons

**PART 2. FITTINGS AND MATERIAL PROVIDED
BY THE ORGANISERS**

Introduction

- m.44.** 1. All electrical judging equipment includes, in addition to the equipment provided by the fencers themselves, the material provided by the organisers of a competition, which is:
2. The central judging apparatus, with extension lamps (cf. m.51, m.59, Annexe B);
 3. The spools, with cables and connections, or cables suspended overhead (cf. m.55);
 4. The conductive piste which neutralises hits made on the ground (cf. m.57);
 5. The source of electrical current (accumulators) (cf. m.58);
 6. For finals of official competitions of the IWF, a clock which counts down the time and which can be linked to the apparatus which controls the audible signal and the electrical registering of hits (cf. m.51, Annexe B).
 7. Additionally to the electrical equipment the organisers have to provide fencing frames as well as lamé aprons for epee fencing including ground cables.

CHAPTER 1. SCORING APPARATUS

Authorised designs

- m.45.** Only electrical apparatus designed with wires connecting the fencers to the central apparatus and registering hits by light signals with auxiliary sound signals are authorised, except for apparatus without wires using encoded waves authorised by the SEMI. This excludes other apparatus based on wireless waves and those which register sound signals only.

Approval of designs of apparatus

- m.46.** 1. Judging apparatus for use in a World Championship or a Paralympic Games must have been approved by the Committee for Electrical Apparatus and Equipment (SEMI) of the FIE.
2. In order to obtain this approval, the apparatus which it is proposed to use must be submitted complete, with spools, connections, etc., for an examination by the said Committee, at a place and on a date to be agreed with the Committee, at least six months before the date of the competition.
 3. The apparatus must be accompanied by a detailed drawing showing its construction.
- m.47.** Approval is given for the use of the apparatus in one specific official competition only. The SEMI Committee is willing, as far as it is able, and without charge, to examine prototypes of apparatus submitted by constructors even if the use of

such apparatus is not envisaged for an imminent official competition.

- m.48.** 1. Approval is given for only one established design of apparatus which conforms to the drawing submitted, and is not given as a general approval for all the products made by any manufacturer. The latter may state in their publicity only the fact that the design of apparatus which they offer for sale has been used at a specific official competition (if this in fact is the case); but they themselves must guarantee that the apparatus conforms to the design for which approval was given.
2. Every approved apparatus must carry, on its base, a metallic plate identifying its specific characteristics: manufacturer, year of manufacture, model, technical information, etc.
- m.49.** The approval of an apparatus by the SEMI Committee as well as its acceptance implies no guarantee against possible faults of construction, or against its use with a source of electrical current other than accumulators (cf. m.58).
- m.50.** All expenses incurred by the SEMI Committee for the examination of apparatus are the responsibility of the persons submitting the apparatus.

Requirements for all electrical equipment (cf. Annexe B)

- m.51.** 1. A hit made on the conductive piste or on the metallic parts of the weapon must not be registered by the apparatus, nor may it prevent the registering of a hit made simultaneously by the opponent. At foil a hit made on a part of the foil may register if an uninsulated part of the weapon of the fencer is in contact with his conductive jacket.
2. The apparatus must not have any device whereby anyone other than the person detailed to supervise it can interrupt its working during a bout.
3. Hits are registered by visual signals. The signal lamps must be placed on the top of the apparatus, in order that they may be visible to the Referee, the competitors and the superintendent of the apparatus. They must be so positioned that they show clearly from which side the hit was made. Arrangements must be made so that extension lamps can be added to the exterior of the apparatus, in order to increase the visibility of the signals.
4. Once the signal lamps are alight, they must so remain until the apparatus is reset, without having any tendency to go out or flicker either when subsequent hits are made or if the apparatus is subjected to vibrations.
5. The visual signals must be accompanied by audible signals (cf. Annexe B).
6. The resetting switches must be placed either on top of or on the front part of the apparatus.
7. a) For official IWF competitions, the source of power must always be accumulators. The wiring of the box to be powered in this way must be designed so that it is impossible for the box to become connected by mistake to the mains supply.
- b) All fencing salles, clubs, etc., and the organisers of training sessions or competitions involving weapons using electrical equipment, may use the current supplied by the mains on condition that they adhere strictly to the technical standards laid down on the subject by their countries and

international communities.

8. a) If the clock is not incorporated in the electrical judging apparatus, the apparatus must have a system for linking in an external clock. This clock must be powered by electricity from a 12 volt accumulator. A disconnection of the wiring which links the clock to the apparatus must cause, simultaneously, the blocking of the apparatus which registers hits, in a manner which preserves what it has registered up to that point, and the stopping of the clock.
b) To allow the apparatus to be used when it is not connected to the clock, there must be a switch in the interior of the apparatus which can change its operating mode (cf. t.32, m.44).
9. For the finals of official IWF competitions, the clock must be equipped with a system which connects it to some external extension clocks displaying large luminous numbers, and with another system for the connection of the audible signal. These two connection systems must be separated from the circuits situated inside the central judging apparatus by means of opto-couplers (cf. t.32, m.44).
10. When the cable connecting the audible-signal apparatus to the clock is disconnected, the audible-signal apparatus must emit a sound of between 80 and 100 decibels (measured at the centre line of the piste) lasting between 2 and 3 seconds, but the central judging apparatus must not be blocked and the clock must not be stopped (cf. t.32, m.44, m.51/9).

Number and quality of judging apparatuses

- m.52.**
1. For official IWF competitions, the organising committee must provide a minimum number of electrical judging apparatuses equal to the number of pistes plus at least two spares. All the apparatuses must be in perfect working order, and of a type approved for the World Championships.
 2. As soon as a member federation is selected to organise an official IWF competition, it would do well to contact the President of the SEMI Committee immediately in order to obtain the names of manufacturers whose electrical apparatus is accepted by the Committee.
 3. The Organising Committee usually prefers combined apparatus, which can be used for all three weapons. The Organising Committee must choose a manufacturer who will provide good quality equipment for the smooth technical running of competitions; this equipment must be approved by the SEMI Committee.
 4. For official IWF competitions, it is compulsory that the apparatus be powered by accumulators without any connection to the main electrical supply.

Checking of apparatuses

- m.53.**
1. Having chosen the manufacturer with which it wants to deal, the Organising Committee immediately advises the President of the SEMI Committee of the FIE who in turn contacts this firm to obtain, as soon as possible, a prototype of the desired model.
 2. The report on the checking of the apparatus is always returned to the

manufacturer by the President of the Committee within one month of the apparatus being received.

3. There are then two possibilities:
 - a) The proposed apparatus is accepted by the Committee, in which case the other apparatuses can be manufactured like the prototype.
 - b) The apparatus does not conform to the requirements, in which case it must be modified and re-submitted to the Committee for a new examination.
4. When all the apparatuses are ready and before they are sent out, the President of the SEMI Committee must be notified, so that he can document the checking of the apparatuses before they leave the factory. Each apparatus comes with a test report giving the different specifications concerning the registering time in milliseconds and the resistance in ohms of the external circuits before registering a non-valid hit.

The person in charge of verification ticks off every apparatus and makes a note of its number.

- m.54.**
1. Before every World Championship or Paralympic Games, a delegate of the SEMI Committee must check the proper working of the apparatuses to be used and that they conform to the type registered. This is independent of the registration of the type of apparatus mentioned above (cf. m.52).
 2. The apparatuses must be made available to this delegate at least 48 hours before the beginning of the competition.

CHAPTER 2. SPOOLS, CABLES AND THEIR CONNECTIONS

- m.55.**
1. The maximum electrical resistance of each wire of the spool, measured from socket to socket, must be 3 ohms.
 2. There must be no interruption of electrical contact even when the spool is being rotated at full speed. To ensure this the contact rings must have double brushes. The wire connected to the blade of the weapon will be connected to the frame of the spool.
 3. The spools must allow 20 m of cable to be unwound without straining the springs.
 4. The socket which terminates the spool cable, and is designed to receive the plug of the bodywire at the fencer's back, must include a safety device which fulfils the following requirements:
 - that it is impossible to use it unless the plug is correctly put in;
 - that it is impossible for it to become separated during the bout;
 - that it is possible for the competitor to verify that the two foregoing requirements are satisfied.
 5. The resistance of each of the three wires in the connecting cables must not exceed 2.5 ohms.

6. The plugs used to connect the bodywire to the spool wire and the connecting cables to the spools and to the apparatus must have three pins of 4 mm diameter arranged in a straight line. The external pins must be spaced 15 and 20 mm respectively from the centre pin. The bodywire and the connecting cables have plugs, the spool wires and the central electrical apparatus have sockets to them.
 7. The use of suspended cables instead of spools is permitted, provided that the conditions already mentioned are satisfied.
- m.56.**
1. The organisers must ensure that the spools have cables of at least 20 m in length so that they do not get ripped out in the event of a flèche made at the end of the piste.
 2. It is desirable for the spools to be placed close to the pistes, but outside them so that fencers do not trip over them.
 3. The cables connecting the spools to the apparatus should be of the three core type and be covered with rubber to protect them from humidity and blows.
 4. Conductive pistes should be earthed at the centre of the piste.
 5. Those in charge of checking equipment during competitions must have a simple and practical device at their disposal to allow them to check quickly that there are no breaks or short-circuits in the three wires of the spools.

CHAPTER 3. CONDUCTIVE PISTES

- m.57.**
1. The conductive piste must be made from metal, metallic mesh or some substance with a base that is conductive. The resistance of the piste, from one end to the other, must not exceed 5 ohms.
 2. The conductive piste must cover the whole of the length and breadth of the piste including its extensions, in order to neutralise floor hits.
 3. a) When the piste is mounted on a platform the conductive piste must cover the whole width of the platform.
 b) The platform must not exceed 50 cm in height, and must be wider than the fencing piste itself by at least 25 cm on each side. Each end of the podium must be equipped with a gentle slope right down to ground level.
 4. a) It is preferable to lay the conductive piste on a wooden base with some flexible material between. It must be provided with some device which enables it to be kept well stretched.
 b) The wooden bases are 12–15 cm above ground level. Their sides must not be sloping.
 c) It is preferable to have a metal strip, screwed down if possible, which will keep down the edges of the conductive piste along the entire length of the base on both sides.

- d) Pistes made of metallic mesh must never be placed directly on a floor of reinforced concrete or tiles.
- 5. The paint used to draw the lines on the conductive piste must not prevent its electrical conductivity, so that a hit made on it at a point where a line occurs is also neutralised.
- 6. The organisers must have equipment for the immediate repair of the piste available on the spot.
- 7. There must be no roller or any sort of obstacle at the ends of the conductive pistes which could prevent the fencers from retreating normally.

CHAPTER 4. SOURCE OF ELECTRICAL CURRENT

- m.58.**
- 1. The apparatus must be based on a 12 volt supply ($\pm 5\%$) or, if the sources of current for each side of the apparatus are separate, on 2×12 volts or 2×6 volts. (The separation of the supply for each side of the apparatus is recommended because it can simplify a number of problems met in the construction of apparatus for foil.)
 - 2. The apparatus may include warning lights to indicate that it is switched on. Such lights should be colourless.
 - 3. If the apparatus is constructed to operate with dry batteries, it must be equipped with a voltmeter or some other device enabling the power in the batteries to be checked at any moment. However, the apparatus must always be equipped with a socket, as described above, to allow it to be powered by accumulators.
 - 4. Generally, there should be two batteries available per apparatus: 12 volt car batteries are used, of 60 or 90 amps/hour.

CHAPTER 5. EXTENSION LAMPS

- m.59.**
- 1.a) Extension lamps outside the apparatus are obligatory for all bouts at Paralympics, World and Zonal Championships as well as for the finals of IWF World Cup competitions.
 - b) The lamps should be placed at a minimum of 1.80 m above the piste. (When the fencers fence on a 0.50 m high podium, the extension lamps must be 2.30 m above ground.)
 - c) The extension lamps signalling valid hits are coloured, one red, the other green, and they should if possible be of 150 watts.
 - 2. a) The white lights indicating non-valid hits may be of only 75 watts.
 - b) The two lamps of the same group must not be further apart than 15 cm and each group must be at least 50 cm from the other.

3. The white and coloured extension lamps must be arranged on either side of the apparatus, either horizontally or vertically, and must be visible from all directions (cf. Annexe B, paragraph A.1.(a).2).
 4. Lamps recording the number of hits scored may not be located alongside the extension lamps.
- m.60.**
1. The exterior lamps of high intensity may be connected to the main electrical supply, but in this case the signals of the recording apparatus have to be separated from the circuits of these lamps by phototransistors or by opto-couplers.
 2. Visual indicators recording the number of hits given by each fencer by means of numbers on the extension lamps are obligatory. These illuminated indicators may operate direct from the main electrical supply.

CHAPTER 6. FENCING FRAMES

m.61. For wheelchair fencing a frame is utilised on each piste. The frame must fulfil the following conditions:

- The frame fixes the wheelchair in a stable position, by securing all wheels of the wheelchair to the frame.
- The wheelchairs are fixed at an angle of $110^{\circ} (\pm 2^{\circ})$ to the central bar.
- The front wheels should touch the central axis in the forward position and all wheels should rest on the base of the frame.
- The frame allows for easy adjustment of the fencing measure to accommodate the varying lengths of the fencers' arms.
- The frame should also be easily adjustable to various widths of wheelchairs. If the wheelchair does not fit in to the frame, a replacement wheelchair that does fit must be used.
- The frame must be easily adjustable for fencers left-handed fencers.
- The frame must also be constructed so that distance, angle, width of wheelchair is fixed and cannot move/change during the bout.
- The frame should stay stable on the ground during a fencer's lunge.

All frames used in official IWF competition must have been approved by the IWF EC.

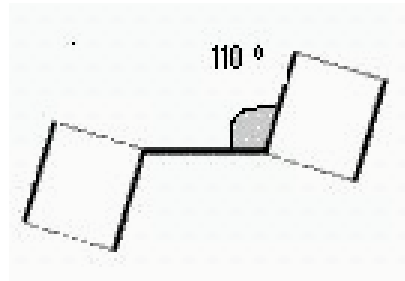

Standard fencing frames for all three weapons

CHAPTER 7. APRONS LAMÉ

- m.62.** To cover the non-valid area in epee fencing, conductive aprons are needed, which must satisfy the following conditions:
- a) The lamé material of the aprons is the same as used for conductive jackets. Therefore it must have the same characteristics regarding electrical resistance etc. (cf. m28.5.a).
 - b) The apron must cover the non-valid area as described in t.62. It should reach to the bottom to make sure that not valid hit can be made at the feet or the lower parts of the wheelchair.
 - c) It must ensure that it will not loosen during the bout. On the other hand it must not disable the fencer in his movements.
 - d) The apron must be earthed by a ground cable to the apparatus or the conductive piste

ANNEXE A TO THE MATERIAL RULES

Manufacturers' Safety Standards for Fencers'

Weapons, Equipment and Clothing

Fencing material used at an official FIE competition and featuring the FIE emblem must, without exception, have obtained a certificate of homologation delivered by the FIE SEMI commission to the manufacturer concerned, certifying that his fencing material complies with FIE Rules.

The following is the material that manufacturers must submit to the SEMI Commission, subsequent to a request in writing for homologation and the authority to mark with the FIE emblem: apparatuses for the signaling of hits, blades, foil and épée points, masks, jackets and breeches, protective plastrons.

To obtain the FIE homologation of a piste, the manufacturer concerned must contact the SEMI and submit a file requesting homologation, including all technical characteristics, and a sample of the piste (30 cm wide x 40 cm long). If the analysis is positive, the SEMI will issue a homologation certificate authorising the manufacturer to mark the piste (from the date of the delivery of the certificate) with the FIE emblem.

For the homologation file of their fencing material to be completed, manufacturers must answer any SEMI requests for information regarding the homologation.

When the SEMI commission has received the file requesting homologation, including the manufacturer's samples and the reports of the different tests tests (from the institutes CRITT, Denkendorf and IFTH for clothing, under-plastrons and masks; and CRITT, Sofranel and Visti for blades), if the analysis is positive they will issue a homologation certificate authorizing the manufacturer to mark his future production (from the date of the delivery of the certificate) with the FIE emblem.

The SEMI must be informed of any modification whatsoever that has the effect of causing a non-conformity to the samples provided for the original homologation.

Obviously the manufacturer must wait for written confirmation of the SEMI Commission's agreement to the proposed modification before launching the new production.

The FIE emblem is a registered trademark. The fact that a piece of equipment carries the FIE emblem attests that the latter has been manufactured in accordance with the prescriptions of the Safety Norms and the Rules of the FIE.

1. WEAPONS

BLADES

SPECIFICATION FOR THE MANUFACTURE OF FENCING BLADES

1. Purpose

This specification refers to the steel that may be used for the construction of blades for fencing, its quality, its manufacturing process, the controls and tests to be conducted.

2. General conditions

The steel used for the manufacture of fencing blades must have the ability to withstand high levels of exertion, a high degree of resistance to breaking and a low susceptibility to corrosion.

3. Characteristics of the material

The structure of the steel, after treatment and manufacturing processing to obtain the finished product, must be smooth and homogeneous.

Faults in the interior or on the surface of the finished product itself are not permitted.

Having definitively established the type of steel being used, the appropriate heat treatments are compulsory.

3.1. Mechanical characteristics

The mechanical characteristics of the steel, after heat treatment, must conform to the requirements in Table I.

Table I. Mechanical characteristics of steel

Rp 0.2 N/mm ²	Rm N/mm ²	A %	Z %	KCU Joule/cm ²	KIC Mpay m	HV
1900	2000	7	35	30	120	500

3.2. Chemical analysis

The allowable limits of the composition of the different elements and impurities for the different types of steel are listed in Table II.

Table II. Chemical composition (in percentage terms)

Element	Type of steel		
	GMG	*	*
C	- 0.03		
S	- 0.0005		
P	- 0.005		
Si	- 0.10		
Mn	- 0.10		
Cr	- 0.50		
Ni	18 => 20		
Mo	4 =>5		
Cu	- 0.30		
Sn	- 0.005		
Al	0.05 =>0		
B	- 0.003		
Co	8 =>13		
Ti	0.5 =>2.0		
Ca	0.005		
Zr	- 0.02		

* Types of steel still the subject of experiment must be included in this table, as they must conform to the characteristics detailed in point 3.1 of the specification.

The FIE has accepted the use of non-Maraging steel of the following types for the manufacture of épée blades:

— 45Si7, 45Si Cr Mo, 45 XH2 MFA.

Blades made with these steels must, obviously, comply with the cycles of resistance to fatigue established by the SEMI.

3.3. Manufacturing process

The products must be subjected to a manufacturing process corresponding to those indicated for the different types of steel in Table III.

Table III. Manufacturing process

Type of steel	Process
GMG	<ol style="list-style-type: none"> 1. Forging at temperatures between 1150°C and 950°C 2. Air-cooling with the blades spaced apart 3. Mechanical machining (removal of extra thickness by reworking) 4. Homogenisation at 950°C ± 10°C for 1 hour 5. Immersion heat treatment at 820°C ± 10°C for 1 hour 6. Air-cooling with the blades separated 7. Ageing at 480°C for 9 hours 8. Air-cooling with the blades separated 9. Tempering
*	
*	

* Types of steel still the subject of experiment must be included in this table, as they must conform to the characteristics detailed in point 3.1 of the specification.

4. Tests and examinations (material)

The tests and examinations to which the steel must be subjected are as follows:

- Chemical analysis
- Traction test
- Ductility tests
- Fracture resistance tests

4.1. Chemical analysis

The sample must have a minimum mass of 50 g. The chemical composition in percentage terms must conform to that laid down in Table II for the corresponding type of steel.

4.2. Traction test

The test must be conducted on a test sample of circular section whose dimensions are indicated at the end of this annexe (Figure A.8), taken from materials that have been subjected to the same heat treatment as specified for materials for the manufacture of the blades.

The tensile strength values must conform to those laid down in Table I.

4.3. Tensile test

The test must be conducted on a test sample with a groove in the form of a V, whose dimensions are indicated at the end of this annexe (Figure A.8), taken in the longitudinal direction from materials that have been subjected to the same heat treatment as specified for materials for the manufacture of the blades.

The value must conform to that laid down in Table I.

4.4. Test of fracture toughness, KIC

The KIC value of the steel must be measured by traction on a CT sample which has the dimensions indicated at the end of this annexe (Table VIII), made from materials subjected to the same thermal treatment as required for the blades, notched mechanically initiating a fatigue crack at the apex of the notch. The test must be conducted according to the methods indicated by the standard ASTM E 399. The value must conform to that laid down in Table I.

In cases where it is not possible to obtain a CT sample, the factor of increasing levels of dynamic loading (KId) may be determined instead of the KIC value.

The test must be conducted on ductility samples with a groove in the form of a 'Charpy V', with dimensions as indicated at the end of this annexe (Table VIII).

The results must conform to the reference standards.

5. Characteristics of the finished product

5.1. Shape

The blades, classified according to the type of weapon, must have the shapes indicated in Annexe A and satisfy the conditions established by the FIE Rules.

5.2. Surface defects

The blades must be free of surface faults which could compromise their use (folds in lamination, cracks, splinters, decarbonisation).

5.3. Surface roughness

At the conclusion of their manufacturing process the blades must be subjected to finishing, to ensure a surface finish of - 0.1 mm. The grinding marks must only extend in the longitudinal direction of the blade.

6. Tests and examinations (finished product)

The tests and examinations to which the steel must be subjected are as follows:

- Chemical analysis
- Traction test
- Ductility test
- Test of fracture toughness, KId
- Hardness test
- Microscopic examination of the structure
- Corrosion test

— Non-destructive control

— Fatigue resistance test

6.1. Chemical analysis

The sample must have a minimum mass of 50 g. The chemical composition in percentage terms must conform to that laid down in Table II for the corresponding type of steel.

6.2. Traction test

The test must be conducted on a sample of circular section, taken from the blade, whose dimensions are indicated at the end of this annexe (Figure A.8).

The values of the tension characteristics must conform to those laid down in Table I.

6.3. Tensile test

The test must be conducted on a sample taken from the blade, without notches, whose dimensions are indicated at the end of this annexe (Figure A.8). The value must conform to that laid down in Table I.

6.4. Test of strength at the fracture point, KId

The KId value must be established by testing on the traction test samples with a groove in the form of a 'Charpy V', with dimensions as indicated at the end of this annexe (Table VIII).

The results must conform to the reference standards.

6.5. Hardness test

The hardness of the material, determined on the exterior surface of the finished product, must conform to that laid down in Table I.

6.6. Microscopic examination of the structure

The examination must be carried out at 500 magnifications on a sample taken from the blade.

The structure submitted must be smooth and homogeneous, conforming to grain dimensions of 7–8 microns in accordance with the standard of reference and corresponding to that resulting from the heat treatment specified in Table III for the corresponding type of steel.

6.7. Non-destructive control

Before being put on the market, all blades must be subjected to a nondestructive control, using an electromagnetic apparatus employing Foucault currents, to explore for surface and below-surface faults. This control is compulsory, and must be carried out over the entire surface of the blade.

6.8. Alternate bending test (optional)

In order to examine the behaviour of blades and the effects induced on the material when the blades are deformed in a plastic manner by the method of alternate bending, new blades selected by chance and supplied from actual production lots must be subjected to test using the special equipment indicated in

the annexe.

The test consists of making a section of the blade bend plastically, in one direction with a radius of inflexion of 60 mm, in the opposite direction with a radius of inflexion of 100 mm, in order to obtain an approximate straightening.

The section of blade involved in the test must be approximately 155 mm long, of which 60 mm from the point must not sustain any deformation.

A cycle consists of one bending plus one straightening. The result of the test is represented by the number of cycles completed before the blade breaks.

To check safety conditions during the normal use of blades, the samples tested must be subjected to a series of alternate bendings at a frequency of not more than 1 Hz (1 Hz = 1 cycle per second), verifying that the blade does not break before:

- 400 cycles for foil;
- 150 cycles for épée,

when the cycles have been conducted in accordance with the method described above.

6.9. Fatigue resistance test (by bending or cyclical buckling)

In order to examine the behaviour of the blades during normal fencing activity, the blades to be tested must undergo a test of their resistance to metal fatigue, with a special apparatus, either mechanical (Baiocco model) or pneumatic (Husarek/Sofranel model). Plans of these two machines may be obtained, on demand, from the SEMI Commission.

The test consists of bending the blade without exceeding the limit of elasticity of the material, i.e. to the point where a bend of approximately 220 mm is reached, corresponding to a shortening of the blade by approximately 250 mm, and then allowing it to straighten.

The test machine must be able to allow the bending and straightening of the blade at a frequency of 1 Hz (1 Hertz = 1 cycle per second).

The test benches are designed to reproduce the stresses to which a blade is subjected in normal fencing activity. The stresses do not go beyond the limits of the elasticity of the blades; a permanent deforming of the blade should not take place. The number of bends to which a blade is subjected before breaking defines its resistance to metal fatigue.

The test benches can be used for bending either without impact (with the end of the blade attached to a revolving support) or with impact (with the end of the blade unattached).

The test should continue until the blade breaks. For the result to be acceptable, it must be ascertained that the blade does not break before:

- 18,000 cycles for foil blades;
- 7,000 cycles for épée blades.

6.10. Evaluation (in percentage terms) of the surface of the progressive fracture

The surface of the fracture obtained at the moment of breaking in the test in points 6.8 and 6.9 above must be analysed in order to measure the extent of the surface over which the rupture has developed progressively.

The measure must be expressed as a percentage of the surface of the entire section subject to the test.

The acceptability of the mechanical characteristics of the blade is confirmed when the measured percentage value is not lower than 15% for foil and 6% for épée.

7. Results of tests and examinations

For each of the tests and examinations detailed in point 6 the results must comply with the following table.

Table IV. Results of tests and examinations

Point of reference	Examination or test	Results
4.1, 6.1	Chemical analysis	Must conform to Table II
4.2, 6.2	Traction test	Must conform to Table I
4.3, 6.3	Tensile test	Must conform to Table I
4.4, 6.4	Test of fracture resistance	Must conform to Table I
6.5	Hardness test	Must conform to Table I
6.6	Microscopic examination of structure	Must conform to point 6.6
6.7	Non-destructive test	Must conform to point 6.7

8. Marking

The identification mark of the manufacturer and the date of manufacture (year and month) must be applied on each blade by cold-stamping near the entry into the guard, to a maximum depth of 0.5 mm.

Note: All the standards may be modified. It is therefore important that manufacturers of blades are absolutely sure that they are in possession of the latest edition or of the latest update page.

2. EQUIPMENT

STANDARDS FOR THE MANUFACTURE OF FENCING MASKS

2.1. MESH OF FENCING MASKS

2.1.1 STANDARDS FOR THE MATERIALS FOR THE MESH OF FENCING MASKS

1. Purpose

These specifications concern the technical quality of the round colddrawn wire of carbon stainless steel intended for the manufacture of the mesh of fencing masks, the processes of its production, and the controls and tests to carry out in its use.

2. General conditions of raw material

The steel intended for the manufacture of the mesh of fencing masks must possess excellent qualities of strength and a high level of elasticity and plastic deformation, as well as a very good resistance against corrosion.

3. Materials

3.1. Chemical composition

The composition of the machined wire to be used to manufacture the wire complying with the present rules, depending on the type of steel chosen, must include the following, in percentage terms.

Table V. Chemical composition

Element	Type of steel		
	304	304 L	321
C	0.03 0.06	< 0.03	< 0.08
Mn	< 2	< 2	< 2
Si	< 1	< 1	< 1
P	< 0.04	< 0.04	< 0.04
S	< 0.03	< 0.03	< 0.03
Cr	18 20	18 20	17 19
Ni	8 10.5	9 12	9 12
Ti			5 ∞ Cmin (< 0.8)

For information, some of the most widely used types of steel are shown above; they satisfy more or less the following defined standards:

- EURONORM 88-71 (EEC)
- UNI 6901-71 (Italy)
- AFNOR NF A 35-572 (France)
- DIN 17440 (Germany)
- BSI PD 6290 (Great Britain)
- MNC 900 E (Sweden)
- JIS G 4306-1972 (Japan)
- GOST 5632-61 (USSR)

3.2. Processing the steel and manufacturing the wire

The method of processing of the steel is entrusted to the supplier. The hot processing to obtain the machined wire must be such that it can ensure a high level of consistency in the materials and an absence of discontinuity and of faults in the interior and on the surface of these same materials.

The process of cold wire drawing, to reduce the section in order to obtain the desired diameter, must provide for adequate intermediate tempering for the manufacture of the tempered materials. In any case the last step of the wire drawing must be preceded by a chemical solution treatment at 1050–1100°C (stainless steel tempering) for types 304 and 304 L or a stabilisation treatment at 850–900°C for type 321.

The last step of the cold wire drawing must involve a hardening process defined commercially as approximately 1/4 hard (H4), with a corresponding reduction in section of 15% and carried out in such a way as to ensure the materials possess the minimum values of the mechanical characteristics indicated in point 3.4.2 of this specification.

3.3. Dimensions of the wire and tolerance

Table VI. Dimensions and tolerance

Diameter (d) (mm)	Tolerance * on d (mm)	Section (mm ²)	Weight per 1000 m (kg)
1.0	± 0.02	0.725	6.28
1.1	± 0.02	0.950	7.50

* The lack of roundness of the wire must not exceed half the tolerance.

Intermediate values of the diameter of the wire are allowed on condition that they conform to the tolerances indicated.

3.4. Conditions of supply

3.4.1. State in which supplied

The wire must be supplied bare with a polished surface: the surface must not show any faults such as scratches, pock marks or other imperfections.

3.4.2. Mechanical characteristics

The values of the mechanical characteristics of the wire which are established at an ambient temperature by the traction test indicated in point 4.1 must be higher than the minimum values shown in Table VII.

Table VII. Mechanical characteristics

Combined loading at breakage	Combined loading of gapping at a proportionality of < 0.2%	Stretching of breakage
R (N/mm ²) min 700	Rp(0.2) (N/mm ²) min 700	^A 50 (%) min 18

4. Tests and examinations

4.1. Traction test

This test must be conducted on samples obtained directly from the wire and in accordance with the conditions indicated by the standards of each country.

4.2. 180° bending test

The test consists of bending the wire to 180° on a 2 mm diameter mandrel.

After the test the wire must not show any small cracks at the point where the bend occurs.

4.3. Micrographic examination of the structure

The examination is conducted on a cross-section of the wire (encased in sufficient resin) at a magnification of x 200 – x 500 after polishing and etching with 10% oxalic acid in accordance with the ASTM 262-70 standard or equivalent.

In practice you should observe a stainless structure with martensite bands; in any case no chrome carbon precipitates may be present on the grain boundaries (see the acceptable structure, in accordance with the ASTM standard already mentioned: 'steep structure').

5. Documents

For the product corresponding to these rules the following documents must be delivered by the manufacturer:

- certificate of conformity of the chemical composition;
- certificate of control of the mechanical characteristics and the results of the bending test and the micrographic examination.

2.1.2. TRANSPARENT MASKS

1. General

The FIE in its standard practices has established the possibility for fencers to use either traditional masks made with metal mesh or transparent masks.

These transparent masks can be of two types:

- composite masks, made using traditional masks, of which a part of the front mesh has been replaced by a visor of transparent plastic;
- masks made entirely of plastic, of which the front part must be transparent.

Currently only composite masks have been accepted by the FIE.

2. Manufacturing norms for transparent masks

The norms are, at present, valid only for composite masks.

The starting point is a metal mesh mask; into the front part of the mesh, at eye level, a window is made by cutting the mesh to a width that may reach as far as the lateral part of the mesh and to a height that may not exceed 12 cm.

The window must be rimmed by a frame of stainless steel, made of two superimposed sections, of which the first is to be soldered to the mesh and the second fixed to the first by bolts.

The transparent visor made of polycarbonate (Lexan) will be placed between the two parts of the frame.

Care must be taken that:

- The thickness of the steel gauge of each part of the frame must be between 0.8 mm and 1.0 mm.
- The edges of the frame which holds down the transparent visor must not be sharp (cutting) and must adhere to the mesh, without any perceptible projections.
- The part of the frame that is soldered must be fixed to the mesh before the window is cut, to ensure that the shape of the mask is not altered when the wires of the mesh are cut.
- The bolts fixing the two parts of the frame must not project beyond the nuts into which they screw.
- The polycarbonate transparent visor (Lexan) must have a minimum thickness of 3.0 mm, and a protective layer against damage to the outside surface is recommended.
- The visor must not have any holes in it, must be shaped when hot, and placed in its location in the frame, under no pressure, when cold and, therefore, without being in any way 'stressed'.
- There must be provision for an anti-condensation system on the inside of the visor, or Lexan treated to this end must be used.
- Because of the damage caused to transparent visors during fencing competitions, it is essential that fencers are able to change the visor of their masks simply and easily.
- The padding of the mask must be reduced as much as possible, using any system which will provide a circulation of air virtually equivalent to that of the traditional mask.
- The total weight of the mask must not exceed 2 kg.

3. Safety standards

All transparent visor masks must provide a high level of safety for fencers.

They must therefore comply with very strict standards and in particular:

- The whole structure of the mask must be rigid and not be distorted as a result of violent shocks.
- The metal mesh and the bib must have the same strength characteristics as those of traditional masks.
- Because of ageing of the plastic material, the polycarbonate visor must only be used for two years after its manufacture and, therefore, the date of manufacture (year and month) must be indicated on it very clearly.

— To avoid degrading the polycarbonate, all contact with chemical agents that can damage the material must be prevented; in particular, any presence of PVC is unacceptable.

— The mask should be kept in a protective bag and it is desirable to avoid putting the mask in the fencing bag (and hence in the aircraft hold) during airplane journeys, but rather to keep it in hand luggage.

4. Homologation of transparent masks and test methods

Before being put on sale and used, all transparent visor masks must be approved and homologated by the SEMI.

4.1. Homologation

To obtain FIE homologation, the manufacturer must send his masks to one of the following three institutes: In Germany "Denkendorf" ; in France CRITT or IFTH. The institute will conduct penetration resistance tests on the metal mesh and the visor in accordance with the CEN norms (e.g. Norm EN 13567).

If the test results are positive, the constructor must send two examples of the mask to be homologated, together with the Institute's certificate, to the headquarters of the SEMI in Lisbon, for the violent-shock tests.

If this result is also positive, the SEMI will issue the homologation certificate to the manufacturer, and the mask may be put on sale and used at official FIE competitions.

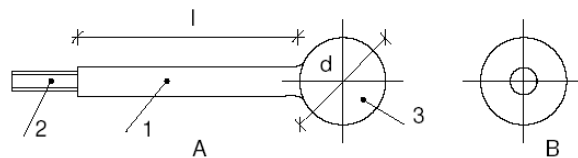

A Side view

l Length of the rod

B End view

d Diameter of the sphere,
20 mm \pm 0.3 mm

1 Rigid rod

2 Attachment point

3 Sphere

Figure A.1. Test rod

4.2. Violent-shock testing

Transparent visor masks must satisfy either the norms established by the CEN Special Commission (cf. the paragraph on masks) or the additional norms established by SEMI relating to resistance to violent shocks.

Therefore, in addition to the tests for resistance to penetration on several parts of the mask as provided for by CEN norms, there is a need for a further test of the resistance of the entire mask to violent shocks, which might occur as a result of

impact with the head or the guard of the opposing fencer.

This test will be carried out in the following manner.

4.2.1. Equipment for the test

The machine to be used must provide for a striker, of variable but known weight, to fall from a height which is also variable, up to a maximum of 2 m.

Fixed to the striker there must be a rod, made of tempered steel, ending in a head in the form of a sphere, with a diameter of 20 mm +/- 0.3 mm.

The rod must be 40–50 mm long and provided with a means of attaching it (normally a thread) to the drop test machine (see Figure A.1).

An appropriate support for the mask must be provided on the base of the test apparatus, to hold the mask firmly during the tests.

On the base of the apparatus, in effect, sliding structures must be in place that can be fixed in an established position, so as to form a sort of rigid box within which the mask is held (see Figure A.2).

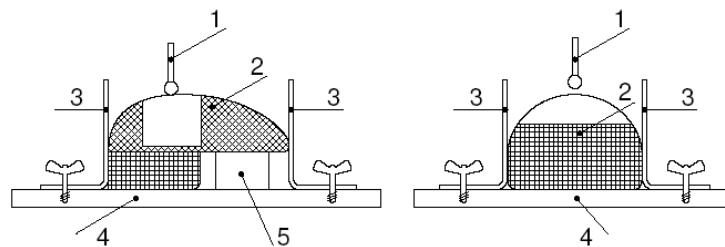

- 1 Rod and sphere
- 2 Mask
- 3 Components to hold mask firmly
- 4 Solid base of test equipment
- 5 Support to keep mask level

Figure A.2. Method of fixing the mask

4.2.2. Drop equipment

The equipment to be used must allow a guided mass weighing between 3 kg and 5 kg to drop from variable heights to achieve a maximum speed of between 5 and 6 m per second at the moment of impact of the striker on the sample to be tested.

A means must be arranged for stopping the drop weight, with the aim that only the rod with the spherical end touches the mask, and not the weight.

The releasing mechanism of the striker must be controlled in such a way as to ensure the same starting conditions, whatever the height of the drop.

The rod, as already specified in 4.2.1, must be fixed to the drop weight.

4.2.3. Sample to be tested

The sample to be tested must be the complete mask, but without the bib and the trimmings.

The mask must be placed on the base of the test apparatus, with the front part turned uppermost.

4.2.4. Successive test cycles

The tests must be conducted in the following order:

1. first test on the visor with the impact point of the sphere on the centre of the mask and on the line crossing the centre of the visor;
2. second test on the same point.

4.2.5. Procedure

1. Fix the mask onto the base of the machine and the rod with the impact sphere onto the drop weight of the drop test apparatus.
2. Place the mask in a such a way as to align the impact point on the mask's visor with the centre of the sphere.
3. Prepare the drop weight for a total weight of 5 kg +/- 0.03 kg, including the rod and the impact sphere.
4. For the first test, raise the drop weight to a height that gives a distance between the sphere and the point of impact on the mask visor of 1600 mm +/- 10 mm, corresponding to a drop energy of 80 joules.
5. Allow the drop weight to fall onto the mask.
6. For the second test, raise the same drop weight to a height of 1800 mm +/- 10 mm, corresponding to a drop energy of 90 joules.
7. Allow the drop weight to fall onto the mask.

4.2.6. Test result

The result of the test is considered positive if the mask resists the two tests without either deformation or damage to the visor itself, or to the frame fixing the visor to the metal mesh.

Only a small impression on the polycarbonate visor, at the point of impact of the test sphere, is acceptable.

2.1.3. MASKS THAT ARE COLOURED OR DECORATED WITH DRAWINGS

Masks may feature coloured designs, on condition that they are approved by the FIE Executive Committee at least 30 days before being used for the first time in an official FIE competition.

2.2. SHAPE, DIMENSIONS AND METHODS OF PRODUCTION OF THE ELEMENTS OF FENCING MASKS

TECHNICAL SPECIFICATION FOR THE MANUFACTURE OF FENCING MASKS

1. Purpose

These technical specifications concern the shape, the dimensions, the methods of production of the essential constituent elements of protective fencing masks, as well as the technical quality of the materials intended for their manufacture.

2. General conditions

All the materials of which fencing masks are made and the corresponding manufacturing processes must ensure an excellent mechanical resistance, a high degree of visibility and comfort for the fencer and a sufficient resistance to wear and tear and ageing.

3. Shape and dimensions of masks

The shape of masks is indicated schematically in Figure A.3 (viewed from the front, from the side and from above). The dimensions of the frontal grille depend on the dimensions of the mask. Those of the side grille must be as follows: the height corresponding to 3/4 that of the front grille; the width being between 10 and 12 cm.

4. Essential constituent elements

The essential elements of the mask, as shown in Figure A.3, are:

- (a) frontal grille protecting the face;
- (b) lateral grille protecting the neck and the nape of the neck;
- (c) strip for reinforcement and to connect the grilles;
- (d) bibs.

The other parts, such as the interior protecting facings, padding, elastic bands and the safety retaining devices, whose production is entrusted to the manufacturer, must entirely conform to the conditions required for their use.

In particular, the rear covering device must ensure that the mask is located in the correct position on the fencer's head and that it remains in a perfect position, even after blows or shocks.

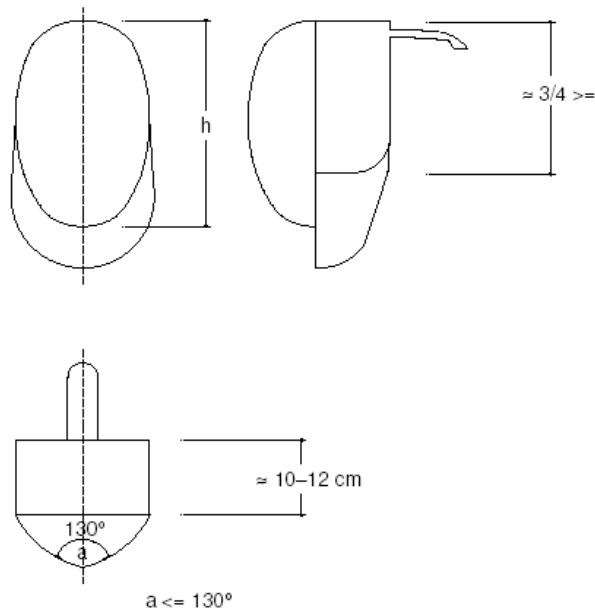

Figure A.3. Design of masks

4.1. Front and side mesh

The mesh must be made of woven material with a square aperture, with an opening of 1.9 mm, made entirely of round stainless steel wire CrNi 18-10 (the technical quality of the wire for which is addressed in Table V).

In the curved zone of the grille the presence of mesh with an opening greater in size than that specified is permissible, on condition that it does not exceed 2.1 mm. The frontal grille must form an interior angle of 130° , corresponding to the fold of the centre line.

4.2. Junction of the frontal and lateral mesh to the reinforcement band

The joining of the frontal mesh to the lateral one, by the reinforcement band, can be accomplished by a mechanical joining (for example metal wire stitching, use of rivets), or by solder.

In the case of solder, which in any case must be done using the usual techniques for stainless steel, the operation must be completed by a careful mechanical polishing of the soldered area, to eliminate slag and residues. The mesh must be entirely covered in paint with a polymer base. Any heat treatments to harden and stabilise the paint must be carried out at a temperature of 400°C .

4.3. Bibs

The bib must be formed from several layers of cloth firmly fixed to each other, of which at least one on the inside must be made of Kevlar fibre or a similar substance; in any case the cloth so formed must ensure a high degree of resistance to penetration equal or greater than 1600 Newtons, to be tested by the methods described in 3.1, below; it must also hinder the forming of stiff creases or the rolling up of the bib itself.

The bib must be fixed to the exterior of the grille starting from the reinforcement band onwards and extending as protection for the neck for a total height of the order of 10–12 cm.

5. Test and certificates

For each model and production series of masks, the manufacturer will send three examples to the SEMI Committee for testing that the mask conforms with the present specifications, as well as photocopies of the certificates delivered by the manufacturer of the mesh.

In the case of a positive result of this test, the manufacturer can place next to the manufacturing mark the following information: 'Conforms with standard ... of the FIE' ('conforme à la norme ... de la FIE').

3. CLOTHING

STANDARDS FOR THE MANUFACTURE OF CLOTHING

For the manufacture of fencing clothing it is obligatory to use material which is able to resist perforation by a force of at least 800 Newtons. This resistance must be verified by the tests defined in the following paragraphs.

3.1. RESISTANCE OF CLOTH AGAINST PERFORATION

STANDARDS FOR TESTING THE RESISTANCE OF CLOTH AGAINST PERFORATION

1. Generalities

The method which is the subject of this standard is intended to determine the resistance against perforation of cloth used to make up fencing uniforms.

The perforation load is defined as the maximum value of impact registered before the sample of cloth is perforated by the test probe: the load is expressed in Newtons or else in kilogrammes of force to one decimal place.

2. Methods of conducting the test

2.1. The test takes place using a high speed dynamometer (as, for example, the INSTROM 1273 apparatus) fitted with a moving test probe 3 mm long, with a square section, a pyramidal head and an angle at the tip of $120\frac{1}{2}$ (see Figure A.4, section A); this probe must be made of high speed or super high speed steel, with a length of 70 mm, of which at least 50 mm juts out from the holding device (see Figure A.4, section B).

2.1.1. The travel of the point must be perpendicular to the surface of the cloth during the course of the test.

2.1.2. The speed of the probe during the test component of its travel must be more than 6 m/s.

2.2. The test must be conducted in a place where the temperature is 20– 25°C and with a relative humidity of 50–55%.

2.3. The samples for the test must be taken from a piece of cloth around 50 cm high, free of faults and obtained at random at a distance of at least 2 m from the ends.

The samples must be square in shape with sides of 14–15 cm and they must be fixed on a device with a double vice (see Figure A.5) while leaving a section of 50 mm diameter free for the test. In the case of fabrics made of several separated layers of cloth, a continuous seam must be sewn along the sides of the square of material which constitutes the sample.

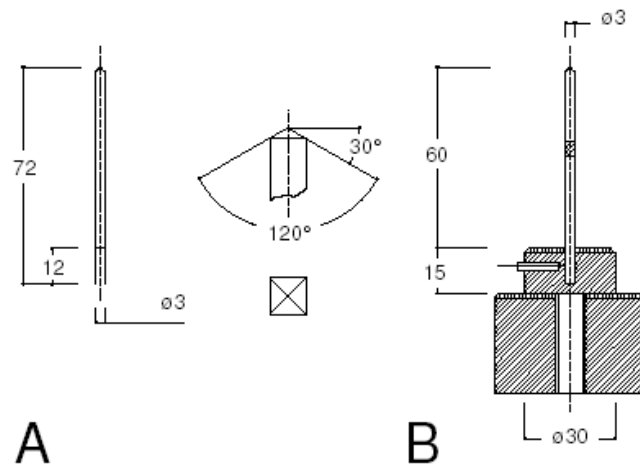

Figure A.4. High speed dynamometer for test of cloth resistance to perforation

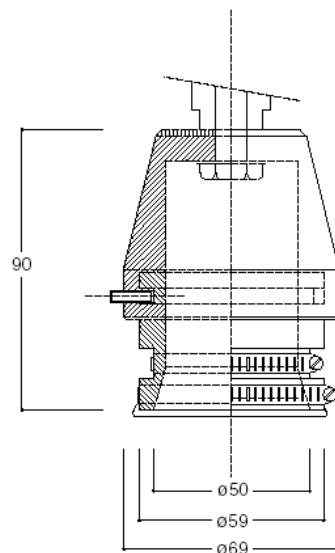

Figure A.5. Fixing device for test of cloth resistance to perforation

2.4. The samples of cloth must be brought to the area where the test will take place at least two hours before the test.

2.5. During the test the force applied by the probe must be registered under the proper conditions of temperature and humidity. The end of the scale for measuring the forces must not be more than 5000 Newtons (with a tolerance of ± 5 Newtons).

2.6. For each cloth, at least three samples must be tested, taken at random from the piece of cloth.

3. Results

The following data must be shown on the certificate confirming that the test has been carried out:

- (a) The name of the company applying, type and brand of cloth;
- (b) The maximum force at the point of penetration for each sample and their average, and the comparative graphic traces of the test;
- (c) The type of dynamometer used, the type and speed of the probe in the test component of its travel, and the conditions of the test (temperature and relative humidity).

3.2. PARTS OF THE FENCER THAT IT IS VITAL TO PROTECT

Extract from the Minutes of the Medical Committee of the FIE

After discussion the Medical Committee considers that the following ought to be considered as 'parts that it is vital to protect'.

— *Above*

The plastron, which is included in the jacket, must protect the neck under the bib (overlapping with this latter), the two hollows above and below the collar bone, the region surrounding the armpit of the sword arm, and that covering the heart.

— *Below*

Protection included in the trousers must cover the abdomen, the two inguinal regions, and the genital organs (by means of a protective cup).

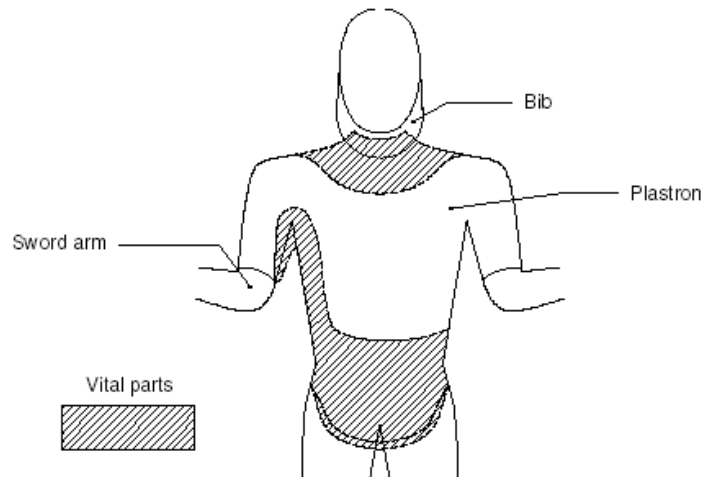

Figure A.6. Vital parts

4. LABEL OF QUALITY

As far as the quality label is concerned, the Committee has established that it must be indelible, must be circular in shape with a diameter of 25 mm for the mask and 50 mm for the uniform, and must include the following data:

- the emblem of the manufacturer;
- the date (year and month) of manufacture;
- the FIE emblem.

On blades, the label must be 7 mm wide.

LABELS ON UNIFORMS



LABELS ON MASKS



LABELS ON BLADES



Figure A.7. FIE quality labels (not to scale)

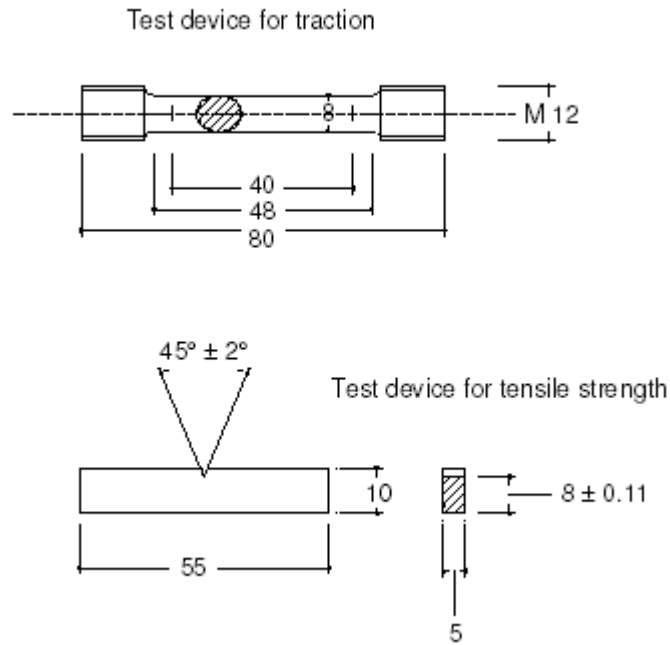

Figure A.8. Test devices for traction and tensile strength

Table VIII. Recommended thicknesses

Rp _{0.2} /E			Thickness recommended B (mm)
From 0.005	0 to 0.005	6	75
From 0.005	7 to 0.006	1	63
From 0.006	2 to 0.006	4	50
From 0.006	5 to 0.006	7	44
From 0.006	8 to 0.007	0	38
From 0.007	1 to 0.007	4	32
From 0.007	5 to 0.007	9	25
From 0.008	0 to 0.008	4	20
From 0.008	5 to 0.009	0	12.5
	0.010	0	6.5

ANNEXE B TO THE MATERIAL RULES

Characteristics of Scoring Apparatus

The installation of a clock and a system for showing the score are both obligatory for the homologation of scoring apparatuses; they must be visible to the spectators.

A. FOIL

1. THE CENTRAL JUDGING APPARATUS (cf. m.51)

(a) Principles

1. The apparatus registers when a break occurs in the circuit of the foil, that is to say that the electrical current which is circulating permanently in the foil circuit is broken when a hit is made.
2. The apparatus will show a red signal on one side and a green signal on the other when a hit is registered on target; white signals on either side will indicate hits off the target.
3. The audible signals will consist either of a short ring, or of a continuous note which will be automatically limited to two seconds. Either sort of sound will occur whenever a visual signal appears. The sound signal must be identical for both sides of the apparatus.
4. After registering a hit, whether on target or off target, the apparatus must no longer be able to register a subsequent hit on the same side of the apparatus.
5. No priority must be indicated between a hit registered against one competitor and a hit registered against his opponent.
6. After a period of time of 300 ms (\pm 25 ms tolerance) after the first hit signalled by the apparatus (this period of time bears no relationship to 'fencing time' which is the basis of judging according to the conventions governing foil fencing), the latter must ignore all signals for subsequent hits.

(b) Sensitivity and regularity

1. Any hit must cause a signal whatever the resistance of the circuits external to the apparatus. The duration of the break of contact which must always ensure that a signal is registered is 14 ms (\pm 1 ms).

Depending on the increase in the resistance, the apparatus may register:

- (1) a valid hit only;
- (2) a valid hit and a non-valid hit simultaneously;
- (3) a non-valid hit only.

The resistance must always be less than 500 ohms for (1) and (2).

2. The registering of a valid hit must be guaranteed when there is a break of contact of 13–15 ms, when the exterior resistance is between 0 and 500 ohms.
3. The contact time is the same for valid and non-valid hits.

A break of contact of duration of 14 ms (\pm 1 ms) must always ensure that a signal is registered, when the exterior resistance is between 0 and 200 ohms.

4. The apparatus must be capable of tolerating an increase in the resistance in the closed circuit of the foils of up to 200 ohms, without causing a 'non-valid' signal to register.

5. Even if the resistance of the foil earth circuit is increased up to 100 ohms, none of the following irregular phenomena must occur:

— that hits are registered on the guard or on the piste;

— that it is possible to register a hit merely by contact of the blade

or the pointe d'arrêt (without depressing it) on the conductive jacket of either competitor.

6. When the blades are in contact, irrespective of the resistance in ohms between them, the apparatus must be capable of registering normally the hits exchanged, valid and non-valid.

7. A specific programme of tests of apparatus under different conditions can be supplied on request by the SEMI Committee of the FIE.

8. A specific programme of tests also includes the checking of the functioning of the yellow lamps.

9. The Congress of the FIE has authorised this Committee to modify or add to the above requirements whenever technical improvements allow the construction of apparatus which can ensure the better operation of the electrical foil judging apparatus.

2. ANTI-BLOCKING TYPE CENTRAL JUDGING APPARATUS

This apparatus must conform to the requirements of the rules set out in Articles m.44–m.51 inclusive, as well as paragraphs (a) 'Principles' and (b) 'Sensitivity and regularity' above, with the exception of point 6 of paragraph (b).

Even if a fault in the insulation in a fencer's equipment causes a short between his conductive jacket and his weapon, the apparatus should still be capable of registering both valid and non-valid hits.

Depending on the resistance of the return circuit of the opponent's foil, the apparatus must register a valid hit up to 200 ohms and non-valid hits above this value.

The apparatus must be equipped with two yellow lamps regulated as follows.

The yellow lamp on the side of either fencer must automatically light up and remain alight as soon as the resistance between the conductive jacket of that fencer and his weapon is less than 450 ohms. When this resistance is in excess of 475 ohms, the yellow lamp should never light up.

These yellow lamps serve only to indicate insulation faults.

If one or both of the yellow lamps remain lit up, the Referee must stop the bout and call the technical experts on duty to eliminate the fault.

The yellow lamps need not indicate any contact between the fencer's conductive jacket and the conductive piste.

B. EPEE

(a) Principle

The apparatus registers when contact is established between the wires forming the circuit in the épée, thus completing the circuit.

(b) Timing

The apparatus must register only the first hit which is made. If the interval of time between two hits is less than 40 ms (1/25th of a second), the apparatus must register a double hit (both signal lamps must light up simultaneously). When the interval is greater than 50 ms (1/20 of a second) the apparatus must register only one hit (only one signal lamp is lit). The tolerance allowed for timing the apparatus is that between these two limits (1/25th and 1/20th of a second).

(c) Sensitivity

When the external resistance is normal, that is 10 ohms, the apparatus must register hits when these are made with a duration of contact of 2–10 ms. With an exceptional external resistance of 100 ohms the apparatus must still register a hit, but without any specific duration of contact.

The apparatus must not register signals of less than 2 ms duration.

(d) Non-registration

The apparatus must not register hits which are made on the earthed material (on the guard or on the conductive piste), even when there is a resistance of 100 ohms in the earth circuit.

(e) Visual signals

1. Visual signals include at least two signal lamps on each side of the apparatus, so designed that if one lamp does not function it does not prevent the other from lighting up nor cause an excessive current through the latter.

2. The signal lamps should give a red signal on one side of the apparatus and a green signal on the other.

3. The apparatus should have a pilot light to show that it is switched on.

This light should be dim and not coloured.

4. The apparatus may include lights which indicate short circuits to earth.

These should be orange in colour.

5. The light-bulbs which show when hits are registered are usually covered with translucent shades. It must, however, be possible to remove these shades and use naked lights, when the light conditions in the locality make it desirable to do so (strong sunlight or, exceptionally, in the open air).

(f) Audible signals

The apparatus must have a loud sound signal. The apparatus may include a device which allows the sound signal to be stopped before the apparatus is reset.

C. SABRE

(a) Principles

1. The apparatus works by contact between the body of the sabre and the conductive surface of the opposing fencer's jacket, glove and mask.

2. For hits made on these valid conductive surfaces, the apparatus shows a red light on one side and a green light on the other.

If the guard or blade of a fencer's sabre is in contact with the conductive surface of his own equipment (signalled by a yellow light), a valid hit made by that fencer must still register.

3. The audible signal will consist of either one short ring or a continuous note lasting 1–2 seconds, concurrent with the light signals. The sound will be the same for both sides of the apparatus.

4. Hits made on the non-conductive surfaces must not be signalled.

5. The apparatus must be equipped with two yellow lamps, one on each side, which will indicate a contact between the guard or blade of a fencer's sabre and the conductive surface of his own equipment.

6. The apparatus must be equipped with two white lamps, identical to those on a foil apparatus, which by their constant illumination, accompanied by a sound signal, indicate any abnormal electrical change in circuits B and C of the fencer at fault.

7. The apparatus must not signal a hit made by the blade whipping over to hit the opponent while in contact with his blade or guard.

8. After a hit has been registered, a subsequent hit made by the other fencer will only be registered if it occurs within a maximum 120 ms (± 10 ms).

The fact that a hit arrived on one fencer before a hit arrived on the other will not be indicated.

9. When the two blades touch, all the other rules should be strictly applied.

10. The SEMI Committee of the FIE reserves the right to change the rules governing the apparatus, either to simplify or to improve its performance.

(b) Sensitivity and regularity

1. The duration of contact during which a signal should be ensured should be 0.1–1 ms. These times may be varied in the light of experience and of laboratory tests carried out by the SEMI Committee.

An apparatus will be rejected if a hit can be registered with a duration of contact of less than 0.1 ms (time subject to modification).

2. The apparatus should allow an increase in the exterior resistance of the connections up to 100 ohms without any drawbacks.

3. Should a fault in the insulation, down to 0 ohms, cause a leakage of current between a fencer's valid conductive surface and his weapon, the apparatus should still be capable of registering all hits exchanged.

The insulation fault will be signalled by the illumination of the yellow lamp on the side of the fencer whose equipment is at fault when the resistance is between 0 and 450 ohms.

The registering of a valid hit on the guard or blade of the fencer at fault will be allowed provided that the electrical resistance between the guard or the blade and the valid surface is less than 250 ohms.

4. The apparatus should still function when the blades are in contact, or if there is contact between the blades and the guards, or between the two guards.

5. If the contact between the blade and the opponent's target takes place 'through the blade', the apparatus:

— will register the hit between 0 and 4 ms (+ 1 ms);

— will prevent the hit being registered between 4 and 15 ms (+ 5 ms), on condition that the contact between the two blades is not interrupted more than a maximum of 10 times in the interval.

6. Should there be a hit made by the whipping over of the blade which has not been signalled, whatever method has been used to prevent the signalling, after 15 ms (\pm 5 ms) from the contact of the blade with the valid target (the time for the registering of the whip) and unless there has been another hit, the apparatus should allow the normal registering of any subsequent hits.

7. A break in the control circuit (defined as more than 250 ohms) for 3 ms \pm 2 ms will be signalled by the illumination of the white lamp on the side of the fencer at fault.

ANNEXE C TO THE MATERIAL RULES

Score-board for Finals

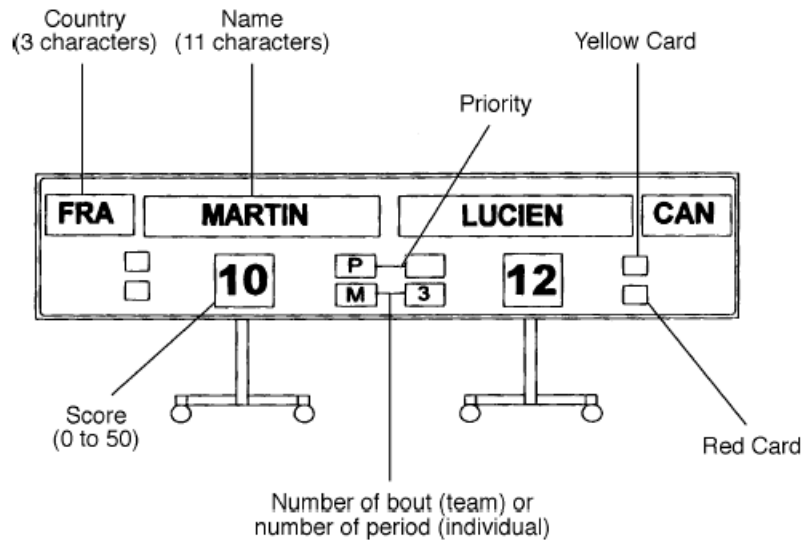

PUBLICITY CODE:

As standing committee of IWAS, IWF follows the IWAS Publicity Code. IWF adopts the FIE Publicity Code as amendment in cases where FIE follows more restrictive regulations or no IWAS regulation is made.